

CDL

$n \approx 2900$ об/
МИН



**Вертикальный
многоступенчатый насос из
нержавеющей стали 304**

Описание товара

- ♦ Вертикальный, многоступенчатый центробежный насос из нержавеющей стали 304
- ♦ Всасывающие и нагнетательные патрубки расположены на одной оси. Легкая установка в линию (in-line)
- ♦ Головная часть насоса и основание насосов CDL изготовлены из чугуна.
- ♦ Рабочее колесо и вал насоса CDL изготовлены из нержавеющей стали.
- ♦ Все проточные детали насоса CDLF изготовлены из нержавеющей стали.
- ♦ Насосы оснащены высокоэффективным двигателем IE3 с классом защиты IP55 F.
- ♦ Качественный подшипник, износостойкое механическое уплотнение.
- ♦ Круглый фланец.
- ♦ Температура жидкости от -10°C до $+120^{\circ}\text{C}$.

Доступные опции по запросу

- ♦ Электродвигатель: Однофазный 230В-50Гц с тепловой защитой, встроенной в обмотку, до $P2 = 2.2\text{kВт}$
- ♦ Датчик РТС

Эксплуатация

Многоступенчатые насосы из нержавеющей стали подходят для промышленных технологических систем, систем промывки, перекачки кислот и щелочей, систем фильтрации, повышения давления воды, очистки воды, ирригации, систем противопожарной защиты и т.п.

Пример

CDL(F) 32 - 30 - 2

2=Количество уменьшенных рабочих колес

30=Количество ступеней x10 (CDL32-CDL90)
Количество ступеней x1 (CDL1-CDL20)

32=Номинальный расход ($\text{м}^3/\text{ч}$)

CDL=Вертикальный многоступенчатый насос общего типа

CDLF=Проточная часть насоса полностью выполнена из SS304

Технические характеристики

50 Гц n≈2900 об/мин

МОДЕЛЬ	DN мм	Мощность кВт лс		380В л/мин м3/ч	Q=Подача															
					25	33	50	67	83	100	117	133	150	167	183	200	217	233	250	267
					1.5	2	3	4	5	6	7	8	9	10	11	12	13	14	15	16
H=Напор (м)																				
CDL 4-2	32x32	0.37	0.5	1	19	18	17	15	13	10	8	-	-	-	-	-	-	-	-	
CDL 4-3	32x32	0.55	0.75	1.4	28	27	26	24	20	18	13	-	-	-	-	-	-	-	-	
CDL 4-4	32x32	0.75	1	1.7	38	36	34	32	27	24	19	-	-	-	-	-	-	-	-	
CDL 4-5	32x32	1.1	1.5	2.4	47	45	43	40	34	31	23	-	-	-	-	-	-	-	-	
CDL 4-6	32x32	1.1	1.5	2.4	56	54	52	48	41	37	28	-	-	-	-	-	-	-	-	
CDL 4-7	32x32	1.5	2	3.2	66	63	61	56	48	43	33	-	-	-	-	-	-	-	-	
CDL 4-8	32x32	1.5	2	3.2	74	72	70	64	55	50	38	-	-	-	-	-	-	-	-	
CDL 4-10	32x32	2.2	3	4.6	96	90	87	81	71	62	48	-	-	-	-	-	-	-	-	
CDL 4-12	32x32	2.2	3	4.6	114	108	104	95	85	75	58	-	-	-	-	-	-	-	-	
CDL 4-14	32x32	3	4	6	136	126	122	112	101	89	68	-	-	-	-	-	-	-	-	
CDL 4-16	32x32	3	4	6	152	144	140	129	115	101	78	-	-	-	-	-	-	-	-	
CDL 4-19	32x32	4	5.5	7.8	183	171	168	153	137	122	93	-	-	-	-	-	-	-	-	
CDL 4-22	32x32	4	5.5	7.8	211	200	192	178	160	138	108	-	-	-	-	-	-	-	-	
CDL 8-2-1	40x40	0.75	1	1.7	-	-	-	-	10	9.5	9.3	9	8.5	8	7	6	-	-	-	
CDL 8-2	40x40	0.75	1	1.7	-	-	-	-	20	19.5	19	18	17	16	14	13	-	-	-	
CDL 8-3	40x40	1.1	1.5	2.4	-	-	-	-	30	29.5	28.5	27	25	24	21	19	-	-	-	
CDL 8-4	40x40	1.5	2	3.2	-	-	-	-	41	39.5	38	36	34	32	28	26	-	-	-	
CDL 8-5	40x40	2.2	3	4.6	-	-	-	-	52	50	48	45	42	40	36	32	-	-	-	
CDL 8-6	40x40	2.2	3	4.6	-	-	-	-	62	60	57	54	51	48	43	39	-	-	-	
CDL 8-8	40x40	3	4	6	-	-	-	-	83	80	77	73	69	65	58	52	-	-	-	
CDL 8-10	40x40	4	5.5	7.8	-	-	-	-	104	100	97	92	87	81	73	65	-	-	-	
CDL 8-12	40x40	4	5.5	7.8	-	-	-	-	124	120	116	111	104	92	87	78	-	-	-	
CDL 8-14	40x40	5.5	7.5	10.6	-	-	-	-	145	141	136	130	122	113	102	92	-	-	-	
CDL 8-16	40x40	5.5	7.5	10.6	-	-	-	-	166	161	156	148	139	130	118	106	-	-	-	
CDL 8-18	40x40	7.5	10	14.4	-	-	-	-	187	182	175	167	157	146	134	120	-	-	-	
CDL 8-20	40x40	7.5	10	14.4	-	-	-	-	208	202	195	186	175	163	150	135	-	-	-	
CDL 10-1	40x40	0.75	1	1.7	-	-	-	-	9.7	9.3	8.9	8.3	7.7	7	6	5	4	-	-	
CDL 10-2	40x40	0.75	1	1.7	-	-	-	-	19.5	19	18	17	16	15	13.5	11.5	10	-	-	
CDL 10-3	40x40	1.1	1.5	2.4	-	-	-	-	29.5	29	28	27	25	23	21	18	16	-	-	
CDL 10-4	40x40	1.5	2	3.2	-	-	-	-	39.5	38.5	37.5	36	34	31	28	25	22	-	-	
CDL 10-5	40x40	2.2	3	4.6	-	-	-	-	49.5	48.5	47	44	42	39	35	32	28	-	-	
CDL 10-6	40x40	2.2	3	4.6	-	-	-	-	60	58	56	54	51	48	43	39	34	-	-	
CDL 10-7	40x40	3	4	6	-	-	-	-	70	68	66	63	60	56	51	45	39	-	-	
CDL 10-8	40x40	3	4	6	-	-	-	-	80	78	75	73	69	64	58	52	44	-	-	
CDL 10-9	40x40	3	4	6	-	-	-	-	90	87	85	81	77	72	66	58	50	-	-	
CDL 10-10	40x40	4	5.5	7.8	-	-	-	-	100	97	95	90	85	80	74	66	56	-	-	
CDL 10-12	40x40	4	5.5	7.8	-	-	-	-	120	117	114	109	104	96	89	79	68	-	-	
CDL 10-14	40x40	5.5	7.5	10.6	-	-	-	-	140	137	134	129	122	113	103	92	79	-	-	
CDL 10-16	40x40	5.5	7.5	10.6	-	-	-	-	160	158	153	148	140	129	119	106	91	-	-	
CDL 10-18	40x40	7.5	10	14.4	-	-	-	-	180	177	172	166	156	145	133	119	102	-	-	
CDL 10-20	40x40	7.5	10	14.4	-	-	-	-	200	196	191	184	173	162	147	132	114	-	-	
CDL 10-22	40x40	7.5	10	14.4	-	-	-	-	220	216	210	202	190	178	162	145	126	-	-	
CDL 12-2	50x50	1.5	2	3.2	-	-	-	-	-	-	23.5	23	22.5	22	21	20	18.5	17	15.5	14
CDL 12-3	50x50	2.2	3	4.6	-	-	-	-	-	-	35.5	35	34	33	31.5	30	28	26	23.5	21
CDL 12-4	50x50	3	4	6	-	-	-	-	-	-	47	46	45	44	42	40	37	34	31	28
CDL 12-5	50x50	3	4	6	-	-	-	-	-	-	59.5	58	56.5	55	52.5	50	46.5	43	39	35
CDL 12-6	50x50	4	5.5	7.8	-	-	-	-	-	-	71.5	70	68	66	63	60	56	52	47	42
CDL 12-7	50x50	5.5	7.5	10.6	-	-	-	-	-	-	83.5	82	79.5	77	73.5	70	65.5	61	55	49
CDL 12-8	50x50	5.5	7.5	10.6	-	-	-	-	-	-	95.5	94	91	88	84	80	75	70	63	56
CDL 12-9	50x50	5.5	7.5	10.6	-	-	-	-	-	-	108	106	103	100	95.5	91	85	79	71.5	64
CDL 12-10	50x50	7.5	10	14.4	-	-	-	-	-	-	120	118	114.5	111	106	101	94.5	88	80	72
CDL 12-12	50x50	7.5	10	14.4	-	-	-	-	-	-	143.5	141	137	133	127	121	113.5	106	96	86
CDL 12-14	50x50	11	15	20.6	-	-	-	-	-	-	168	165	160	155	148	141	132.5	124	112	100
CDL 12-16	50x50	11	15	20.6	-	-	-	-	-	-	192.5	189	183.5	178	170	162	152	142	128.5	115
CDL 12-18	50x50	11	15	20.6	-	-	-	-	-	-	217	213	207.5	202	192.5	183	171.5	160	145	130

Также верно для CDLF

Технические характеристики

50 Гц n≈2900 об/мин

МОДЕЛЬ	DN мм	Мощность		380В А	Q=Подача																
		кВт	лс		л/мин м3/ч	133	167	200	233	267	300	333	367	400	433	467	533	600	667		
						8.0	10	12	14	16	18	20	22	24	26	28	32	36	40		
					H=Напор (м)																
CDL 16-2	50x50	2.2	3	4.6	27	26	25	24	22	21	19	16	-	-	-	-	-	-			
CDL 16-3	50x50	3	4	6	41	40	38	37	34	32	29	25	-	-	-	-	-	-			
CDL 16-4	50x50	4	5.5	7.8	54	53	52	49	46	43	38	34	-	-	-	-	-	-			
CDL 16-5	50x50	5.5	7.5	10.6	68	67	65	62	58	54	48	43	-	-	-	-	-	-			
CDL 16-6	50x50	5.5	7.5	10.6	82	80	78	74	70	64	58	52	-	-	-	-	-	-			
CDL 16-7	50x50	7.5	10	14.4	96	95	91	87	82	76	68	61	-	-	-	-	-	-			
CDL 16-8	50x50	7.5	10	14.4	110	108	104	99	94	86	77	70	-	-	-	-	-	-			
CDL 16-10	50x50	11	15	20.6	138	136	131	125	118	109	97	87	-	-	-	-	-	-			
CDL 16-12	50x50	11	15	20.6	166	162	157	150	141	130	116	105	-	-	-	-	-	-			
CDL 16-14	50x50	15	20	27.9	194	190	184	175	166	152	136	122	-	-	-	-	-	-			
CDL 16-16	50x50	15	20	27.9	222	217	210	200	189	174	156	140	-	-	-	-	-	-			
CDL 20-1	50x50	1.1	1.5	2.4	-	13.5	13	12.5	12	11	10	9	8	7	6	-	-	-			
CDL 20-2	50x50	2.2	3	4.6	-	27	26.5	26	25	24	23	22	20	18	15	-	-	-			
CDL 20-3	50x50	4	5.5	7.8	-	40	39.5	39	38	37	35	33	30	27	24	-	-	-			
CDL 20-4	50x50	5.5	7.5	10.6	-	54	53	52	51	49	47	44	41	37	33	-	-	-			
CDL 20-5	50x50	5.5	7.5	10.6	-	67	66	64	62	60	58	55	50	45	40	-	-	-			
CDL 20-6	50x50	7.5	10	14.4	-	81	79	77	75	73	70	66	61	55	49	-	-	-			
CDL 20-7	50x50	7.5	10	14.4	-	95	93	91	89	86	82	77	71	65	58	-	-	-			
CDL 20-8	50x50	11	15	20.6	-	109	107	105	102	99	94	89	82	75	67	-	-	-			
CDL 20-10	50x50	11	15	20.6	-	136	134	131	128	124	118	111	103	95	85	-	-	-			
CDL 20-12	50x50	15	20	27.9	-	164	162	158	154	149	142	133	124	114	102	-	-	-			
CDL 20-14	50x50	15	20	27.9	-	192	189	185	180	174	166	156	145	133	119	-	-	-			
CDL 20-17	50x50	18.5	25	34.2	-	234	230	225	219	212	202	190	177	162	145	-	-	-			
CDL 32-10-1	65x65	1.5	2	3.2	-	-	-	-	14	14	13	13	12	12	11	9	7	4			
CDL 32-10	65x65	2.2	3	4.6	-	-	-	-	18	18	17	16	15	15	14	13	11	8			
CDL 32-20-2	65x65	3	4	6	-	-	-	-	29	29	28	27	26	25	23	20	16	11			
CDL 32-20	65x65	4	5.5	7.8	-	-	-	-	36	35	34	33	32	31	29	27	23	18			
CDL 32-30-2	65x65	5.5	7.5	10.6	-	-	-	-	47	46	44	43	41	40	38	33	28	21			
CDL 32-30	65x65	5.5	7.5	10.6	-	-	-	-	54	53	51	50	48	46	44	40	35	27			
CDL 32-40-2	65x65	7.5	10	14.4	-	-	-	-	65	64	62	60	58	56	53	46	40	30			
CDL 32-40	65x65	7.5	10	14.4	-	-	-	-	72	71	69	67	65	62	59	53	47	37			
CDL 32-50-2	65x65	11	15	20.6	-	-	-	-	83	81	79	77	74	71	68	60	52	41			
CDL 32-50	65x65	11	15	20.6	-	-	-	-	90	88	86	84	81	78	74	67	59	47			
CDL 32-60-2	65x65	11	15	20.6	-	-	-	-	101	99	97	94	90	87	83	74	65	51			
CDL 32-60	65x65	11	15	20.6	-	-	-	-	108	106	104	101	97	94	90	81	72	57			
CDL 32-70-2	65x65	15	20	27.9	-	-	-	-	119	117	114	111	107	103	98	88	78	60			
CDL 32-70	65x65	15	20	27.9	-	-	-	-	126	124	121	117	113	109	105	95	85	67			
CDL 32-80-2	65x65	15	20	27.9	-	-	-	-	136	134	131	127	123	119	114	102	90	71			
CDL 32-80	65x65	15	20	27.9	-	-	-	-	144	141	138	134	130	125	120	109	97	77			
CDL 32-90-2	65x65	18.5	25	34.2	-	-	-	-	154	151	148	144	140	135	129	117	102	82			
CDL 32-90	65x65	18.5	25	34.2	-	-	-	-	162	159	156	152	147	142	136	124	109	88			
CDL 32-100-2	65x65	18.5	25	34.2	-	-	-	-	175	171	166	162	157	152	146	131	115	91			
CDL 32-100	65x65	18.5	25	34.2	-	-	-	-	182	178	173	169	164	158	152	138	122	98			
CDL 32-110-2	65x65	22	30	40.5	-	-	-	-	193	189	184	179	173	169	164	146	128	102			
CDL 32-110	65x65	22	30	40.5	-	-	-	-	200	196	191	186	180	174	168	153	135	109			
CDL 32-120-2	65x65	22	30	40.5	-	-	-	-	211	206	201	195	189	184	178	160	140	113			
CDL 32-120	65x65	22	30	40.5	-	-	-	-	218	213	208	202	196	190	184	167	147	120			
CDL 32-130-2	65x65	30	40	54.9	-	-	-	-	230	224	218	212	206	200	193	174	153	124			
CDL 32-130	65x65	30	40	54.9	-	-	-	-	237	231	225	219	213	207	200	181	160	131			
CDL 32-140-2	65x65	30	40	54.9	-	-	-	-	247	241	235	229	222	216	210	189	165	135			
CDL 32-140	65x65	30	40	54.9	-	-	-	-	255	249	242	236	229	223	216	196	172	142			
CDL 32-150-2	65x65	30	40	54.9	-	-	-	-	266	260	253	246	239	232	224	203	178	145			
CDL 32-150	65x65	30	40	54.9	-	-	-	-	274	267	260	253	246	239	231	210	185	152			
CDL 32-160-2	65x65	30	40	54.9	-	-	-	-	284	277	270	263	255	248	240	218	190	156			
CDL 32-160	65x65	30	40	54.9	-	-	-	-	292	285	277	270	262	254	246	225	197	163			

Также верно для CDLF

МОДЕЛЬ	DN мм	Мощность			380В А	Q=Подача																		
		кВт	лс	л/мин		H=Напор (м)																		
						417 м3/ч	500 25	583 30	667 35	700 40	750 42	833 45	917 50	1000 55	1083 60	1167 65	1333 70	1417 80	1500 85	1667 90	1833 100	1833 110		
CDL 45-10-1	80x80	3	4	6	20	19	18	17	16	15	13	11	-	-	-	-	-	-	-	-				
CDL 45-10	80x80	4	5.5	7.8	24	23	22	21	20	19	18	16	-	-	-	-	-	-	-	-				
CDL 45-20-2	80x80	5.5	7.5	10.6	40	38	36	33	32	30	27	23	-	-	-	-	-	-	-	-				
CDL 45-20	80x80	7.5	10	14.4	48	46	44	42	41	39	35	31	-	-	-	-	-	-	-	-				
CDL 45-30-2	80x80	11	15	20.6	63	61	58	54	52	50	44	38	-	-	-	-	-	-	-	-				
CDL 45-30	80x80	11	15	20.6	71	69	66	63	61	58	53	47	-	-	-	-	-	-	-	-				
CDL 45-40-2	80x80	15	20	27.9	87	84	80	75	73	69	62	54	-	-	-	-	-	-	-	-				
CDL 45-40	80x80	15	20	27.9	95	92	88	84	81	78	71	62	-	-	-	-	-	-	-	-				
CDL 45-50-2	80x80	18.5	25	34.2	111	107	102	96	93	88	80	69	-	-	-	-	-	-	-	-				
CDL 45-50	80x80	18.5	25	34.2	119	115	110	105	101	97	88	78	-	-	-	-	-	-	-	-				
CDL 45-60-2	80x80	22	30	40.5	135	130	124	117	113	108	97	85	-	-	-	-	-	-	-	-				
CDL 45-60	80x80	22	30	40.5	143	138	132	125	122	116	106	93	-	-	-	-	-	-	-	-				
CDL 45-70-2	80x80	30	40	54.9	158	152	146	138	134	127	115	100	-	-	-	-	-	-	-	-				
CDL 45-70	80x80	30	40	54.9	166	161	154	146	142	135	124	109	-	-	-	-	-	-	-	-				
CDL 45-80-2	80x80	30	40	54.9	182	175	168	159	154	146	133	116	-	-	-	-	-	-	-	-				
CDL 45-80	80x80	30	40	54.9	190	184	176	167	162	154	141	124	-	-	-	-	-	-	-	-				
CDL 45-90-2	80x80	30	40	54.9	205	198	190	180	174	166	150	132	-	-	-	-	-	-	-	-				
CDL 45-90	80x80	37	50	67.4	214	207	198	188	183	174	159	140	-	-	-	-	-	-	-	-				
CDL 45-100-2	80x80	37	50	67.4	230	221	212	200	194	185	168	147	-	-	-	-	-	-	-	-				
CDL 45-100	80x80	37	50	67.4	238	230	220	209	203	193	177	155	-	-	-	-	-	-	-	-				
CDL 45-110-2	80x80	45	60	80.8	255	246	236	223	217	206	188	165	-	-	-	-	-	-	-	-				
CDL 45-110	80x80	45	60	80.8	263	255	244	232	225	214	196	173	-	-	-	-	-	-	-	-				
CDL 45-120-2	80x80	45	60	80.8	280	270	259	245	238	226	206	181	-	-	-	-	-	-	-	-				
CDL 45-120	80x80	45	60	80.8	289	280	268	255	247	236	216	190	-	-	-	-	-	-	-	-				
CDL 45-130-2	80x80	45	60	80.8	305	294	282	267	259	247	225	198	-	-	-	-	-	-	-	-				
CDL 64-10-1	100x100	4	5.5	7.8	-	19	19	18	18	17	16	15	14	13	11	8	-	-	-	-				
CDL 64-10	100x100	5.5	7.5	10.6	-	27	26	25	25	24	23	22	21	20	18	15	-	-	-	-				
CDL 64-20-2	100x100	7.5	10	14.4	-	39	38	36	36	35	33	31	29	26	23	17	-	-	-	-				
CDL 64-20-1	100x100	11	15	20.6	-	46	45	44	43	42	40	38	36	33	30	24	-	-	-	-				
CDL 64-20	100x100	11	15	20.6	-	53	52	51	50	49	47	45	43	40	37	30	-	-	-	-				
CDL 64-30-2	100x100	15	20	27.9	-	66	64	62	61	59	56	53	50	46	41	32	-	-	-	-				
CDL 64-30-1	100x100	15	20	27.9	-	73	71	69	68	66	63	60	57	53	48	39	-	-	-	-				
CDL 64-30	100x100	18.5	25	34.2	-	80	78	76	75	73	70	67	64	60	55	46	-	-	-	-				
CDL 64-40-2	100x100	18.5	25	34.2	-	92	90	87	86	84	80	76	71	66	60	47	-	-	-	-				
CDL 64-40-1	100x100	22	30	40.5	-	100	97	94	93	91	87	83	78	73	67	54	-	-	-	-				
CDL 64-40	100x100	22	30	40.5	-	107	104	101	100	98	94	90	85	80	74	61	-	-	-	-				
CDL 64-50-2	100x100	30	40	54.9	-	121	118	114	112	110	105	100	95	88	80	64	-	-	-	-				
CDL 64-50-1	100x100	30	40	54.9	-	128	125	121	119	117	112	107	102	95	87	71	-	-	-	-				
CDL 64-50	100x100	30	40	54.9	-	136	133	129	127	124	119	114	109	102	94	78	-	-	-	-				
CDL 64-60-2	100x100	30	40	54.9	-	150	146	142	140	137	131	125	118	110	101	81	-	-	-	-				
CDL 64-60-1	100x100	37	50	67.4	-	157	153	149	147	144	138	132	125	117	108	88	-	-	-	-				
CDL 64-60	100x100	37	50	67.4	-	164	160	156	154	151	145	139	132	124	115	95	-	-	-	-				
CDL 64-70-2	100x100	37	50	67.4	-	179	174	169	167	163	156	149	141	132	121	99	-	-	-	-				
CDL 64-70-1	100x100	37	50	67.4	-	186	181	176	174	170	163	156	148	139	128	106	-	-	-	-				
CDL 64-70	100x100	45	60	80.8	-	193	188	183	181	177	170	163	155	146	135	112	-	-	-	-				
CDL 64-80-2	100x100	45	60	80.8	-	207	202	196	193	189	182	173	164	154	142	116	-	-	-	-				
CDL 64-80-1	100x100	45	60	80.8	-	215	209	203	200	196	189	180	171	161	149	123	-	-	-	-				
CDL 90-10-1	100x100	5.5	7.5	10.6	-	-	-	-	-	-	22	21	19	18	17	16	14	13	10	6				
CDL 90-10	100x100	7.5	10	14.4	-	-	-	-	-	-	25	25	24	23	22	21	20	19	16	12				
CDL 90-20-2	100x100	11	15	20.6	-	-	-	-	-	-	41	40	39	38	36	32	30	28	22	15				
CDL 90-20	100x100	15	20	27.9	-	-	-	-	-	-	53	52	50	49	47	44	41	40	36	30				
CDL 90-30-2	100x100	18.5	25	34.2	-	-	-	-	-	-	68	67	65	63	60	55	52	49	41	32				
CDL 90-30	100x100	22	30	40.5	-	-	-	-	-	-	81	79	77	75	72	67	64	62	55	48				
CDL 90-40-2	100x100	30	40	54.9	-	-	-	-	-	-	98	96	93	90	87	80	75	72	62	50				
CDL 90-40	100x100	30	40	54.9	-	-	-	-	-	-	110	108	105	103	100	92	86	84	76	66				
CDL 90-50-2	100x100	37	50	67.4	-	-	-	-	-	-	126	123	120	117	113	104	98	93	81	68				
CDL 90-50	100x100	37	50	67.4	-	-	-	-	-	-	139	135	131	128	124	115	110	106	94	83				
CDL 90-60-2	100x100	45	60	80.8	-	-	-	-	-	-	155	152	148	144	139	129	122	117	102	86				
CDL 90-60	100x100	45	60	80.8	-	-	-	-	-	-	168	164	160	155	150	141	134	130	117	103				

Также верно для CDLF

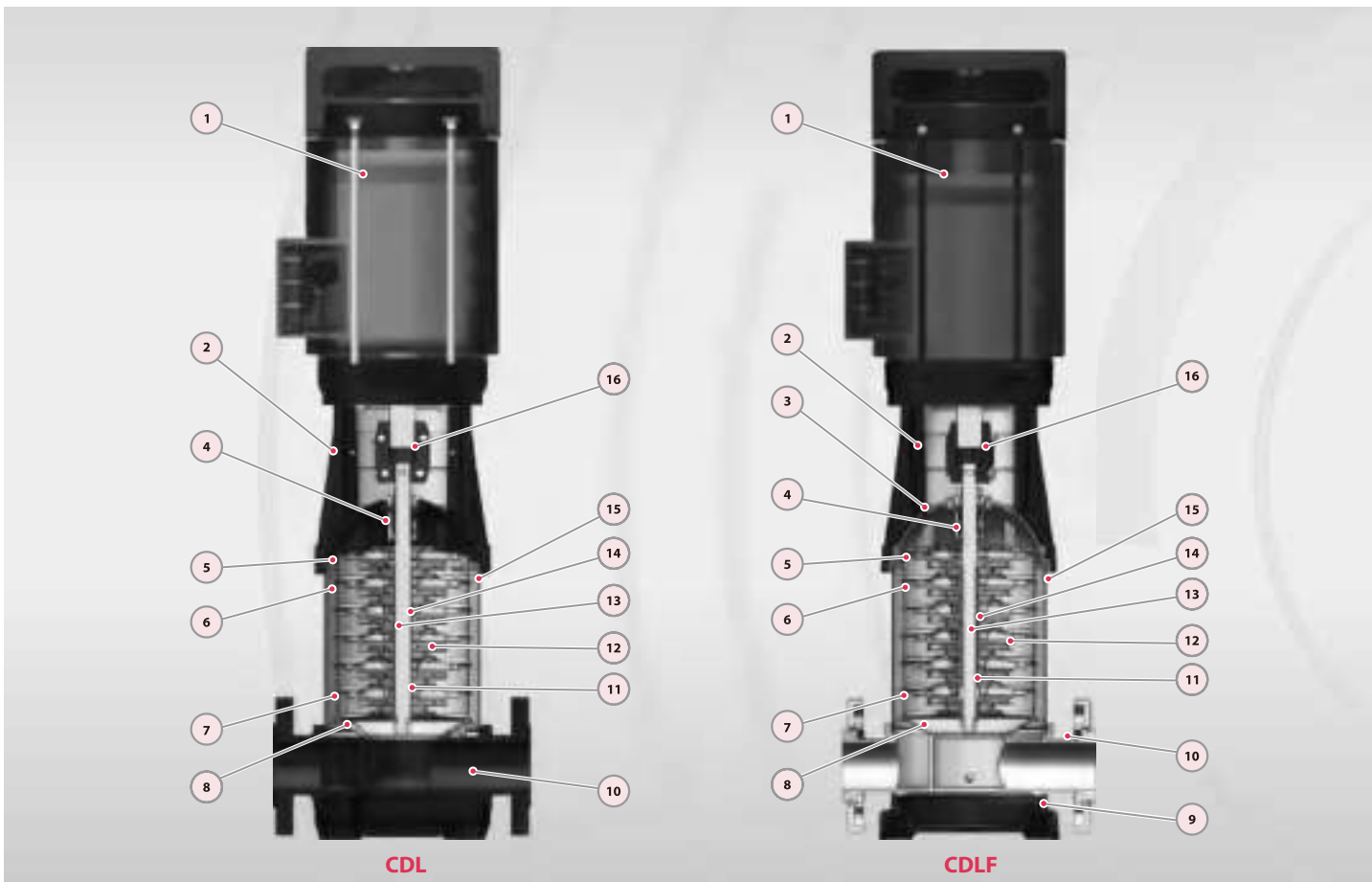
Используемые материалы

No.	Описание	Материал
1	Двигатель	IP55 класс F
2	Корпус насоса	Чугун
3	Уплотнение	Нержавеющая сталь 304
4	Механическое уплотнение	Графит-Карбид Вольфрама – Витон
5	Верхний диффузор	Нержавеющая сталь 304
6	Диффузор	Нержавеющая сталь 304
7	Поддерживающий диффузор	Нержавеющая сталь 304
8	Индуктор	Нержавеющая сталь 304

No.	Описание	Материал
9	Подставка	Чугун
10	Впускная и выпускная камеры	CDL: чугун CDLF: Нержавеющая сталь 304
11	Подшипник	Карбид вольфрама
12	Рабочее колесо	Нержавеющая сталь 304
13	Вал	Нержавеющая сталь 304
14	Втулка рабочего колеса	Нержавеющая сталь 304
15	Цилиндр	Нержавеющая сталь 304
16	Муфта	Углеродистая сталь



Технические характеристики

50Hz n ≈ 2900об/мин

МОДЕЛЬ	DN мм	Мощность			380В А	Q=Подача																				
		кВт	лс	л/мин 1000 м3/ч																						
						60	70	80	90	100	110	120	130	140	150	160	170	180	200	220	240					
H=Напор (м)																										
CDL120-10	125x125	11	15	20.6	22	21.8	21.6	21	20.5	19.5	18.5	17	16	15	-	-	-	-	-	-	-	-	-	-	-	-
CDL120-20-2	125x125	15	20	27.9	34	33.6	33	31	30.2	30	28.5	27	25	24	-	-	-	-	-	-	-	-	-	-	-	-
CDL120-20-1	125x125	18.5	25	34.2	41	40	39.5	38.5	37	36.5	34.5	32.5	30	27.5	-	-	-	-	-	-	-	-	-	-	-	-
CDL120-20	125x125	22	30	40.5	46	45	44.5	43.5	42.4	41	40	38	36	33.5	-	-	-	-	-	-	-	-	-	-	-	-
CDL120-30-2	125x125	30	40	54.9	57	56	55	53.5	52	51	49	46.5	43.5	41	-	-	-	-	-	-	-	-	-	-	-	-
CDL120-30-1	125x125	30	40	54.9	64	63	62	60	58.5	57.5	55.5	52	49	46	-	-	-	-	-	-	-	-	-	-	-	-
CDL120-30	125x125	30	40	54.9	69.5	68.5	67.5	66	64.4	62.5	61	57.5	54.5	51	-	-	-	-	-	-	-	-	-	-	-	-
CDL120-40-2	125x125	37	50	67.4	80.5	79	78	76	73.5	72	69	66	61.5	58	-	-	-	-	-	-	-	-	-	-	-	-
CDL120-40-1	125x125	37	50	67.4	87	86	84.5	82	80	78	76	72	68	64.5	-	-	-	-	-	-	-	-	-	-	-	-
CDL120-40	125x125	45	60	80.8	92.5	91	90	88	85.5	83	81	77	73	68.5	-	-	-	-	-	-	-	-	-	-	-	-
CDL120-50-2	125x125	45	60	80.8	104.5	103	101	99	96	93	90	85.5	80.5	75.5	-	-	-	-	-	-	-	-	-	-	-	-
CDL120-50-1	125x125	45	60	80.8	110.5	109	107.5	105	102	100	97	92	86.5	83	-	-	-	-	-	-	-	-	-	-	-	-
CDL120-50	125x125	55	75	98.5	115.5	114	113	110	107.5	104.5	101.5	96	91	86	-	-	-	-	-	-	-	-	-	-	-	-
CDL120-60-2	125x125	55	75	98.5	128	125.5	123	121	117.3	113.5	110	104.5	98.5	92.5	-	-	-	-	-	-	-	-	-	-	-	-
CDL120-60-1	125x125	55	75	98.5	134	132	130.5	127	124	121	118	111	105	100	-	-	-	-	-	-	-	-	-	-	-	-
CDL120-60	125x125	75	100	133.7	139	137	135	132	128.8	126	123	116	110	104	-	-	-	-	-	-	-	-	-	-	-	-
CDL120-70-2	125x125	75	100	133.7	151	148	145.5	143	138.6	134	130	123.5	116.5	109	-	-	-	-	-	-	-	-	-	-	-	-
CDL120-70-1	125x125	75	100	133.7	156.5	154	152	148.5	144.5	141	137.5	130	123	116.5	-	-	-	-	-	-	-	-	-	-	-	-
CDL120-70	125x125	75	100	133.7	162.5	160.5	158.5	155	151	148	145	137	129	123	-	-	-	-	-	-	-	-	-	-	-	-

Размер и вес

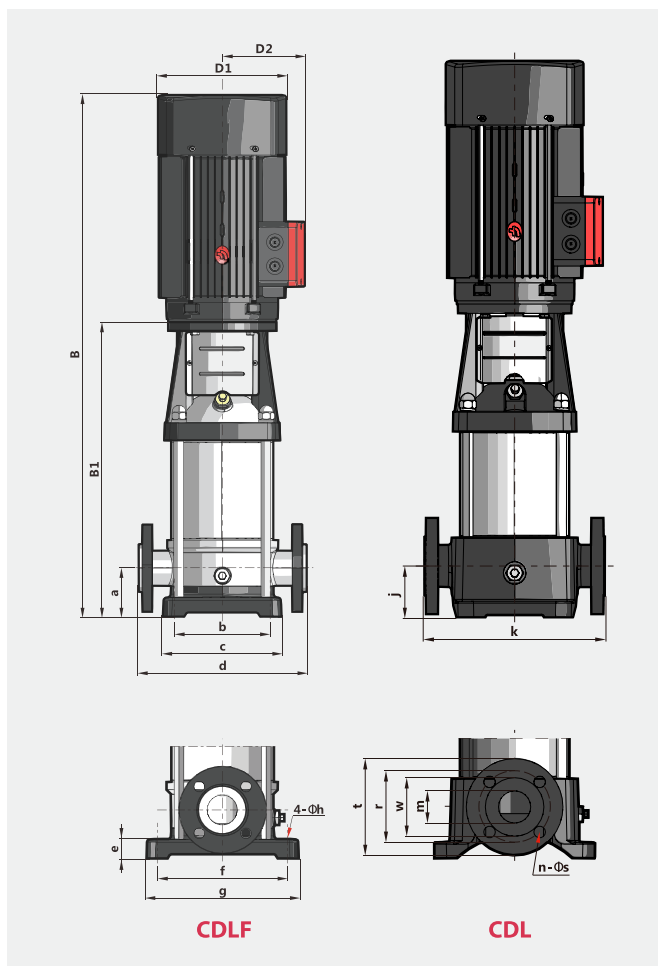

МОДЕЛЬ	B1 мм	B мм	D1 мм	D2 мм	Общее, мм	кг
CDL120-10	840	1340	330	255	DN=125 a=180 b=275 c=340 d=380 e=40 f=380 g=472 h=18 j=180 k=380 m=125 n=8 s=28 r=220 t=270 w=175	230
CDL120-20-2	1000	1500	330	255		245
CDL120-20-1	1000	1550	330	255		250
CDL120-20	1000	1575	360	285		285
CDL120-30-2	1160	1810	400	310		360
CDL120-30-1	1160	1810	400	310		360
CDL120-30	1160	1810	400	310		360
CDL120-40-2	1320	1970	400	310		400
CDL120-40-1	1320	1970	400	310		400
CDL120-40	1320	2005	460	340		460
CDL120-50-2	1480	2165	460	340		470
CDL120-50-1	1480	2165	460	340		470
CDL120-50	1510	2270	540	370		575
CDL120-60-2	1670	2430	540	370		585
CDL120-60-1	1670	2430	540	370	585	
CDL120-60	1670	2515	580	410	705	
CDL120-70-2	1830	2675	580	410	715	
CDL120-70-1	1830	2675	580	410	715	
CDL120-70	1830	2675	580	410	715	

МОДЕЛЬ	DN мм	Мощность		380В А	Q=Подача															
		кВт	лс		л/мин 1000															
					м3/ч															
					H=Напор (м)															
					60	70	80	90	100	110	120	130	140	150	160	170	180	200	220	240
CDL150-10-1	125x125	11	15	20.6	-	-	18.3	17.8	17.3	17	16	15	14	12.5	11	10	8.5	-	-	-
CDL150-10	125x125	15	20	27.9	-	-	24	23	22.5	22	21.5	20.5	20	18.5	17	16	15	-	-	-
CDL150-20-2	125x125	18.5	25	34.2	-	-	37	35.5	34	33	32	31	29	27.5	26	23	21	-	-	-
CDL150-20-1	125x125	22	30	40.5	-	-	44.3	43	42	40	39	38.5	37.5	35	33	30	27	-	-	-
CDL150-20	125x125	30	40	54.9	-	-	50	49	48	47	45.5	44	42	40	37	34	32	-	-	-
CDL150-30-2	125x125	30	40	54.9	-	-	63.5	61	59	57.5	56	54.5	53	49	45.5	42	39	-	-	-
CDL150-30-1	125x125	37	50	67.4	-	-	70	68	67	65	63	62	60	56	53	49	45	-	-	-
CDL150-30	125x125	37	50	67.4	-	-	78	76.5	75	73	70.5	68	66	63	59	55	50.5	-	-	-
CDL150-40-2	125x125	45	60	80.8	-	-	89	87	84	81.5	79	77	74.5	70.5	65.5	60	56	-	-	-
CDL150-40-1	125x125	45	60	80.8	-	-	96.5	94	91.5	89	86.5	84	81.5	77	72.5	67	62	-	-	-
CDL150-40	125x125	55	75	98.5	-	-	104	102	100	97	95	91	88	84	79.5	74	68	-	-	-
CDL150-50-2	125x125	55	75	98.5	-	-	115.5	112	109	106	102.5	100	97	92	86	79	73.5	-	-	-
CDL150-50-1	125x125	75	100	133.7	-	-	122.5	119.5	117	113.5	111.5	107.5	104.5	99	93.5	87	80	-	-	-
CDL150-50	125x125	75	100	133.7	-	-	130	127.5	125	121	119	115	111.5	106.5	101	94.5	86.5	-	-	-
CDL150-60-2	125x125	75	100	133.7	-	-	140	137	133	130	126	121	118	112	106	98	91	-	-	-
CDL150-60-1	125x125	75	100	133.7	-	-	148.5	145	141.7	137.5	135	131	127	120.5	114.5	106.5	97.5	-	-	-
CDL150-60	125x125	75	100	133.7	-	-	157	153	149	145	142	139.5	137	130	123.5	116	109	-	-	-

Размер и вес

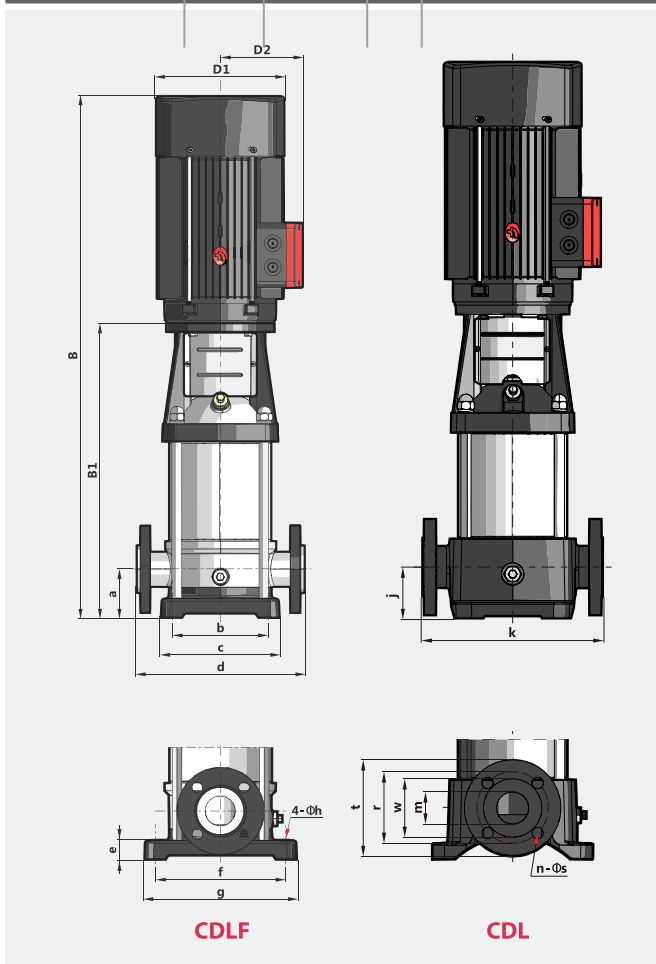

МОДЕЛЬ	B1 мм	B мм	D1 мм	D2 мм	Общее, мм	кг
CDL150-10-1	840	1340	330	255	DN=125 a=180 b=275 c=340 d=380 e=40 f=380 g=472 h=18 j=180 k=380 m=125 n=8 s=28 r=220 t=270 w=175	230
CDL150-10	840	1340	330	255		235
CDL150-20-2	1000	1550	330	255		250
CDL150-20-1	1000	1575	360	285		295
CDL150-20	1000	1650	400	310		350
CDL150-30-2	1160	1810	400	310		360
CDL150-30-1	1160	1810	400	310		360
CDL150-30	1160	1810	400	310		385
CDL150-40-2	1320	2005	460	340		460
CDL150-40-1	1320	2005	460	340		460
CDL150-40	1350	2110	540	370		560
CDL150-50-2	1510	2270	540	370		570
CDL150-50-1	1510	2355	580	410		690
CDL150-50	1510	2355	580	410		690
CDL150-60-2	1670	2515	580	410		700
CDL150-60-1	1670	2515	580	410		700
CDL150-60	1670	2515	580	410	700	

МОДЕЛЬ	DN мм	Мощность		380В А	Q=Подача															
		кВт	лс		Н=Напор (м)															
					л/мин м3/ч	1000 60	1167 70	1333 80	1500 90	1667 100	1833 110	2000 120	2167 130	2333 140	2500 150	2667 160	2833 170	3000 180	3333 200	3667 220
CDL200-10-B	150x150	18.5	25	34.2	-	-	-	-	25.5	25	25	25	24	24	23	22	21.5	20	18	15.5
CDL200-10-A	150x150	22	30	40.5	-	-	-	-	29	29	28.5	28	27.5	27	26.5	26	25.5	24	22	20
CDL200-10	150x150	30	40	54.9	-	-	-	-	38.5	38	38	38	37.5	37	36.5	36	35	34	32.5	30
CDL200-20-2B	150x150	37	50	67.4	-	-	-	-	53	52	51	50	49	48	47	46	44	41	37	32
CDL200-20-2A	150x150	45	60	80.8	-	-	-	-	59.5	59	58	57	56	55	54	53	52.5	49	44.5	40.5
CDL200-20-A	150x150	55	75	98.5	-	-	-	-	69	69	68	67	66	65	64	63	62	59	55.5	51
CDL200-20	150x150	55	75	98.5	-	-	-	-	78.5	78	77.5	77	76	75	74	73	71.5	69	66	61.5
CDL200-30-2B	150x150	75	100	133.7	-	-	-	-	91.5	90	89	88	86.5	85	83.5	81	79	75	70	63
CDL200-30-A-B	150x150	75	100	133.7	-	-	-	-	95	94	93	92	90	89	87	85	83.5	79	73.5	67
CDL200-30-2A	150x150	75	100	133.7	-	-	-	-	99.5	99	97.5	96	94.5	93	91.5	90	89	84	78.5	72
CDL200-30-B	150x150	75	100	133.7	-	-	-	-	104.5	104	102.5	101	100	99	97	95	93	89	84.5	77.5
CDL200-30-A	150x150	75	100	133.7	-	-	-	-	108	107	106	105	103.5	102	100.5	99	97.5	93	88	81.5
CDL200-30	150x150	90	125	159.9	-	-	-	-	117.5	117	116	115	113.5	112	110.5	109	107	103	99	92
CDL200-40-2B	150x150	90	125	159.9	-	-	-	-	131.5	130	129	127	125.5	123	121	118	115.5	110	103.5	94
CDL200-40-2A	150x150	110	150	195.1	-	-	-	-	138.5	137	136	134	132	130	128	126	124	118	111	102.5
CDL200-40-A	150x150	110	150	195.1	-	-	-	-	148	147	145.5	144	142.5	140	138	136	134	128	122	113
CDL200-40	150x150	110	150	195.1	-	-	-	-	157.5	157	155.5	154	152.5	150	148	146	143.5	138	132.5	123.5

Размер и вес

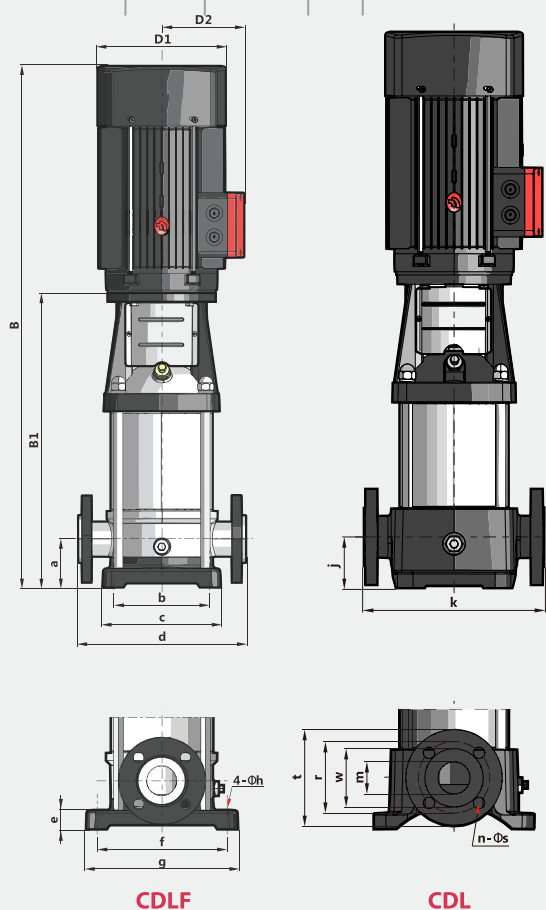

МОДЕЛЬ	B1 мм	B мм	D1 мм	D2 мм	Общие, мм	кг
CDL200-10-B	907	1457	330	255	DN=150 a=200 b=385 c=460 d=490 e=40 f=500 g=600 h=20 j=200 k=490 m=150 n=8 s=28 r=250 t=300 w=203	311
CDL200-10-A	907	1482	360	285		347
CDL200-10	907	1557	400	310		403
CDL200-20-2B	1101	1751	400	310		447
CDL200-20-2A	1101	1786	460	340		504
CDL200-20-A	1131	1891	540	370		595
CDL200-20	1131	1891	540	370		595
CDL200-30-2B	1325	2170	580	410		748
CDL200-30-A-B	1325	2170	580	410		748
CDL200-30-2A	1325	2170	580	410		748
CDL200-30-B	1325	2170	580	410		748
CDL200-30-A	1325	2170	580	410		748
CDL200-30	1325	2220	580	410		817
CDL200-40-2B	1519	2414	580	410		830
CDL200-40-2A	1519	2659	645	550		1180
CDL200-40-A	1519	2659	645	550		1180
CDL200-40	1519	2659	645	550	1180	

Размер и вес

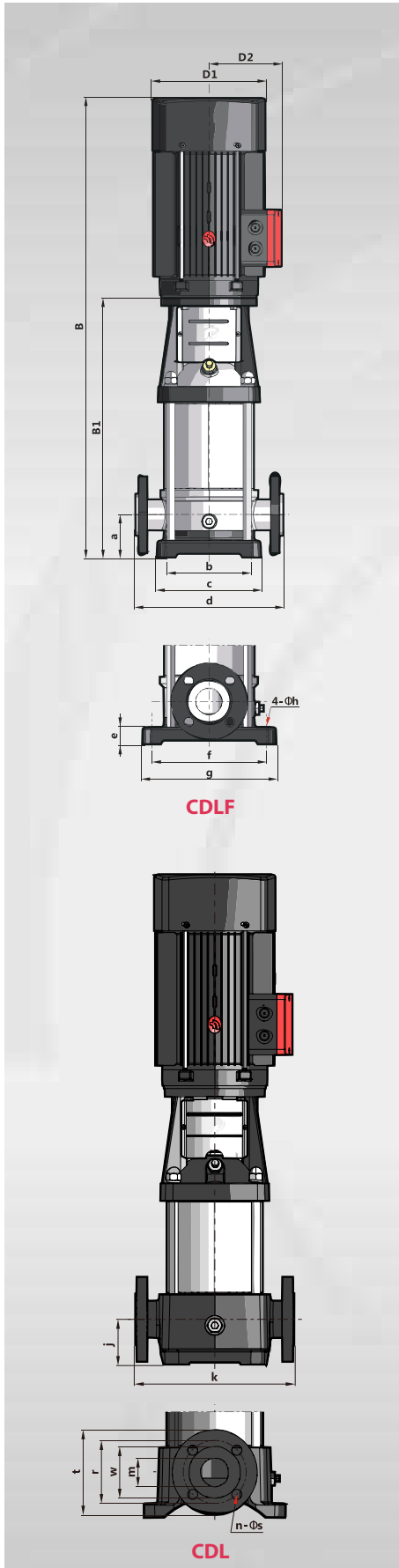

Модель	B1 мм	B мм	D1 мм	D2 мм	Общее, мм	кг
1-2	258	483	148	117		20
1-3	276	501	148	117		20
1-4	294	519	148	117		21
1-5	312	537	148	117		21
1-6	330	555	148	117		22
1-7	348	573	148	117		23
1-8	366	591	148	117		24
1-9	384	609	148	117		25
1-10	402	627	148	117		26
1-11	420	645	148	117		26
1-12	448	693	170	142		29
1-13	466	711	170	142		30
1-15	502	747	170	142		31
1-17	538	783	170	142		33
1-19	574	819	170	142		34
1-21	610	855	170	142		35
1-23	646	891	170	142		36
1-25	692	982	190	155		42
1-27	728	1018	190	155		43
1-30	782	1072	190	155		45
1-33	836	1126	190	155		49
1-36	890	1180	190	155		51
2-2	258	483	148	117	DN=25	20
2-3	276	501	148	117	a=50	20
2-4	294	519	148	117	b=100	22
2-5	312	537	148	117	c=150	23
2-6	340	585	170	142	d=210	26
2-7	358	603	170	142	e=20	26
2-9	394	639	170	142	f=180	26
2-11	430	675	170	142	g=210	28
2-13	476	766	190	155	h=13	29
2-15	512	802	190	155	j=75	35
2-18	566	856	190	155	k=250	36
2-22	638	928	190	155	m=32	41
2-26	720	1065	197	165	n=4	42
3-2	258	483	148	117	r=85	20
3-3	276	501	148	117	s=14	20
3-4	294	519	148	117	t=115	21
3-5	312	537	148	117	w=60	21
3-6	330	555	148	117		23
3-7	348	573	148	117		24
3-8	376	621	170	142		27
3-9	394	639	170	142		28
3-10	412	657	170	142		28
3-11	430	675	170	142		29
3-12	448	693	170	142		30
3-13	466	711	170	142		31
3-15	502	747	170	142		32
3-17	548	838	190	155		38
3-19	584	874	190	155		39
3-21	620	910	190	155		42
3-23	656	946	190	155		43
3-25	692	982	190	155		44
3-27	728	1018	190	155		45
3-29	764	1054	190	155		46
3-31	810	1155	197	165		54
3-33	846	1191	197	165		55
3-36	900	1245	197	165		57

Модель	B1 мм	B мм	D1 мм	D2 мм	Общее мм	кг
4-2	276	501	148	117	DN=32	21
4-3	303	528	148	117	a=50	22
4-4	340	585	170	142	b=100	25
4-5	367	612	170	142	c=150	27
4-6	394	639	170	142	d=210	27
4-7	431	721	190	155	e=20	33
4-8	458	748	190	155	f=180	33
4-10	512	802	190	155	g=210	37
4-12	566	856	190	155	h=13	38
4-14	630	975	197	165	j=75	46
4-16	684	1029	197	165	k=250	48
4-19	765	1120	230	188	m=32	57
4-22	846	1201	230	188	n=4	59
8-2-1	347	592	170	142	r=100	32
8-2	347	592	170	142	s=18	32
8-3	377	622	170	142	t=140	34
8-4	417	707	190	155	w=60	40
8-5	447	737	190	155		44
8-6	477	767	190	155		45
8-8	547	892	197	165		53
8-10	607	962	230	188		64
8-12	667	1022	230	188	DN=40	66
8-14	747	1137	260	208	a=80	81
8-16	807	1197	260	208	b=130	84
8-18	867	1257	260	208	c=199	93
8-20	927	1317	260	208	d=260	94
10-1	347	592	170	142	e=25	40
10-2	347	592	170	142	f=215	41
10-3	377	622	170	142	g=247	43
10-4	417	707	190	155	h=14	49
10-5	447	737	190	155	j=80	53
10-6	477	767	190	155	k=280	54
10-7	517	862	197	165	m=50	64
10-8	547	892	197	165	n=4	65
10-9	577	922	197	165	r=110	66
10-10	607	962	230	188	s=18	74
10-12	667	1022	230	188	t=150	76
10-14	747	1137	260	208	w=80	100
10-16	807	1197	260	208		102
10-18	867	1257	260	208		107
10-20	927	1317	260	208		109
10-22	987	1377	260	208		111
12-2	367	657	190	155	DN=50	39
12-3	397	687	190	155	a=90	43
12-4	437	782	197	165	b=130	51
12-5	467	812	197	165	c=199	53
12-6	497	852	230	188	d=260	61
12-7	547	937	260	208	e=35	73
12-8	577	967	260	208	f=215	74
12-9	607	997	260	208	g=247	76
12-10	637	1027	260	208	h=14	83
12-12	697	1087	260	208	j=90	87
12-14	845	1345	330	255	k=300	157
12-16	905	1405	330	255	m=50	161
12-18	965	1465	330	255	n=4	164

Размер и вес

Модель	B1 мм	B мм	D1 мм	D2 мм	Общее, мм	кг	Модель	B1 мм	B мм	D1 мм	D2 мм	Общее, мм	кг
16-2	397	687	190	155	DN=50 a=90 b=130 c=199 d=260 e=35 f=215 g=247 h=14 j=90 k=300 m=50 n=4 r=125 s=18 t=165 w=80	42	45-10-1	561	906	197	165	DN=80 a=140 b=190 c=245 d=365 e=45 f=266 g=330 h=14 j=140 k=365 m=80 n=8 r=160 s=18 t=200 w=120	83
16-3	452	797	197	165		50	45-10	561	916	230	188		90
16-4	497	852	230	188		59	45-20-2	641	1031	260	208		105
16-5	562	952	260	208		76	45-20	641	1031	260	208		110
16-6	607	997	260	208		77	45-30-2	826	1326	330	255		183
16-7	652	1042	260	208		84	45-30	826	1326	330	255		183
16-8	697	1087	260	208		86	45-40-2	906	1406	330	255		197
16-10	875	1375	330	255		158	45-40	906	1406	330	255		197
16-12	965	1465	330	255		161	45-50-2	986	1536	330	255		221
16-14	1055	1555	330	255		174	45-50	986	1536	330	255		221
16-16	1145	1645	330	255		178	45-60-2	1066	1641	360	285		261
20-1	387	632	170	142		33	45-60	1066	1641	360	285		261
20-2	397	687	190	155		42	45-70-2	1146	1796	400	310		320
20-3	452	807	230	188		58	45-70	1146	1796	400	310		320
20-4	517	907	260	208		74	45-80-2	1226	1876	400	310		324
20-5	562	952	260	208		76	45-80	1226	1876	400	310		324
20-6	607	997	260	208		82	45-90-2	1306	1956	400	310		328
20-7	652	1042	260	208		84	45-90	1306	1956	400	310		352
20-8	785	1285	330	255		153	45-100-2	1386	2036	400	310		355
20-10	875	1375	330	255		157	45-100	1386	2036	400	310		355
20-12	965	1465	330	255	170	45-110-2	1466	2151	450	345	426		
20-14	1055	1555	330	255	172	45-110	1466	2151	450	345	426		
20-17	1190	1740	330	255	195	45-120-2	1546	2231	450	345	432		
32-10-1	505	795	190	155	64	45-120	1546	2231	450	345	432		
32-10	505	795	190	155	68	45-130-2	1626	2311	450	345	438		
32-20-2	575	920	197	165	77	64-10-1	561	916	230	188	93		
32-20	575	930	230	188	85	64-10	561	951	260	208	105		
32-30-2	645	1035	260	208	100	64-20-2	644	1034	260	208	110		
32-30	645	1035	260	208	100	64-20-1	754	1254	330	255	182		
32-40-2	715	1105	260	208	109	64-20	754	1254	330	255	182		
32-40	715	1105	260	208	109	64-30-2	836	1336	330	255	196		
32-50-2	890	1390	330	255	181	64-30-1	836	1336	330	255	197		
32-50	890	1390	330	255	181	64-30	836	1386	330	255	221		
32-60-2	960	1460	330	255	185	65-40-2	919	1469	330	255	225		
32-60	960	1460	330	255	185	64-40-1	919	1494	360	285	258		
32-70-2	1030	1530	330	255	199	64-40	919	1494	360	285	258		
32-70	1030	1530	330	255	199	64-50-2	1001	1651	400	310	319		
32-80-2	1100	1600	330	255	203	64-50-1	1001	1651	400	310	319		
32-80	1100	1600	330	255	203	64-50	1001	1651	400	310	320		
32-90-2	1170	1720	330	255	222	64-60-2	1084	1734	400	310	325		
32-90	1170	1720	330	255	222	64-60-1	1084	1734	400	310	325		
32-100-2	1240	1790	330	255	227	64-60	1084	1734	400	310	349		
32-100	1240	1790	330	255	227	64-70-2	1166	1816	400	310	349		
32-110-2	1310	1885	360	285	272	64-70-1	1166	1816	400	310	353		
32-110	1310	1885	360	285	272	64-70	1166	1851	460	340	353		
32-120-2	1380	1955	360	285	276	64-80-2	1248	1933	460	340	420		
32-120	1380	1955	360	285	276	64-80-1	1248	1933	460	340	424		
32-130-2	1450	2100	400	310	337	90-10-1	571	961	260	208	105		
32-130	1450	2100	400	310	337	90-10	571	961	260	208	110		
32-140-2	1520	2170	400	310	341	90-20-2	773	1273	330	255	181		
32-140	1520	2170	400	310	341	90-20	773	1273	330	255	192		
32-150-2	1590	2240	400	310	345	90-30-2	865	1415	330	255	215		
32-150	1590	2240	400	310	345	90-30	865	1440	360	285	252		
32-160-2	1660	2310	400	310	350	90-40-2	957	1607	400	310	312		
32-160	1660	2310	400	310	350	90-40	957	1607	400	310	312		
							90-50-2	1049	1699	400	310	336	
							90-50	1049	1699	400	310	336	
							90-60-2	1141	1826	460	340	407	
							90-60	1141	1826	460	340	407	

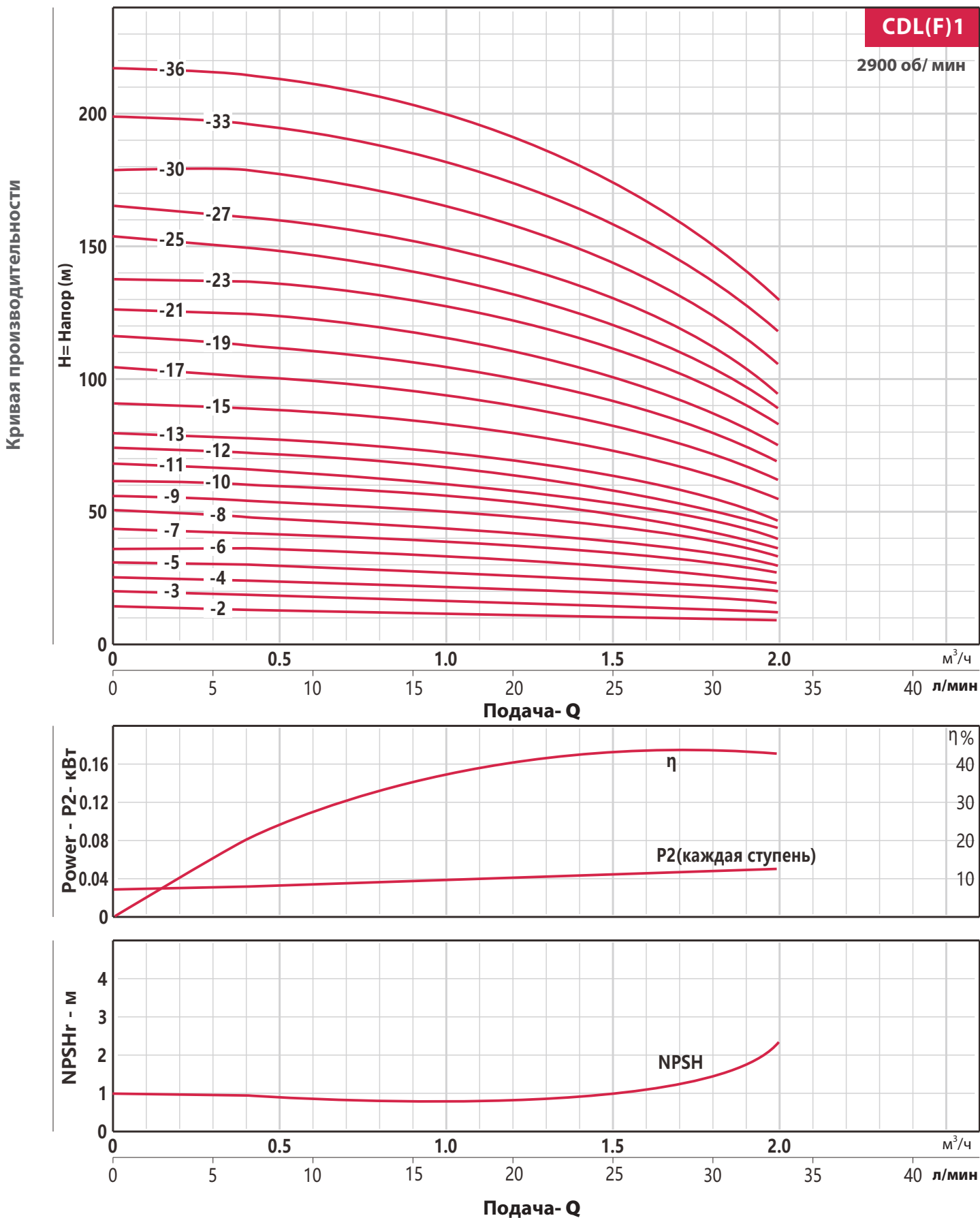

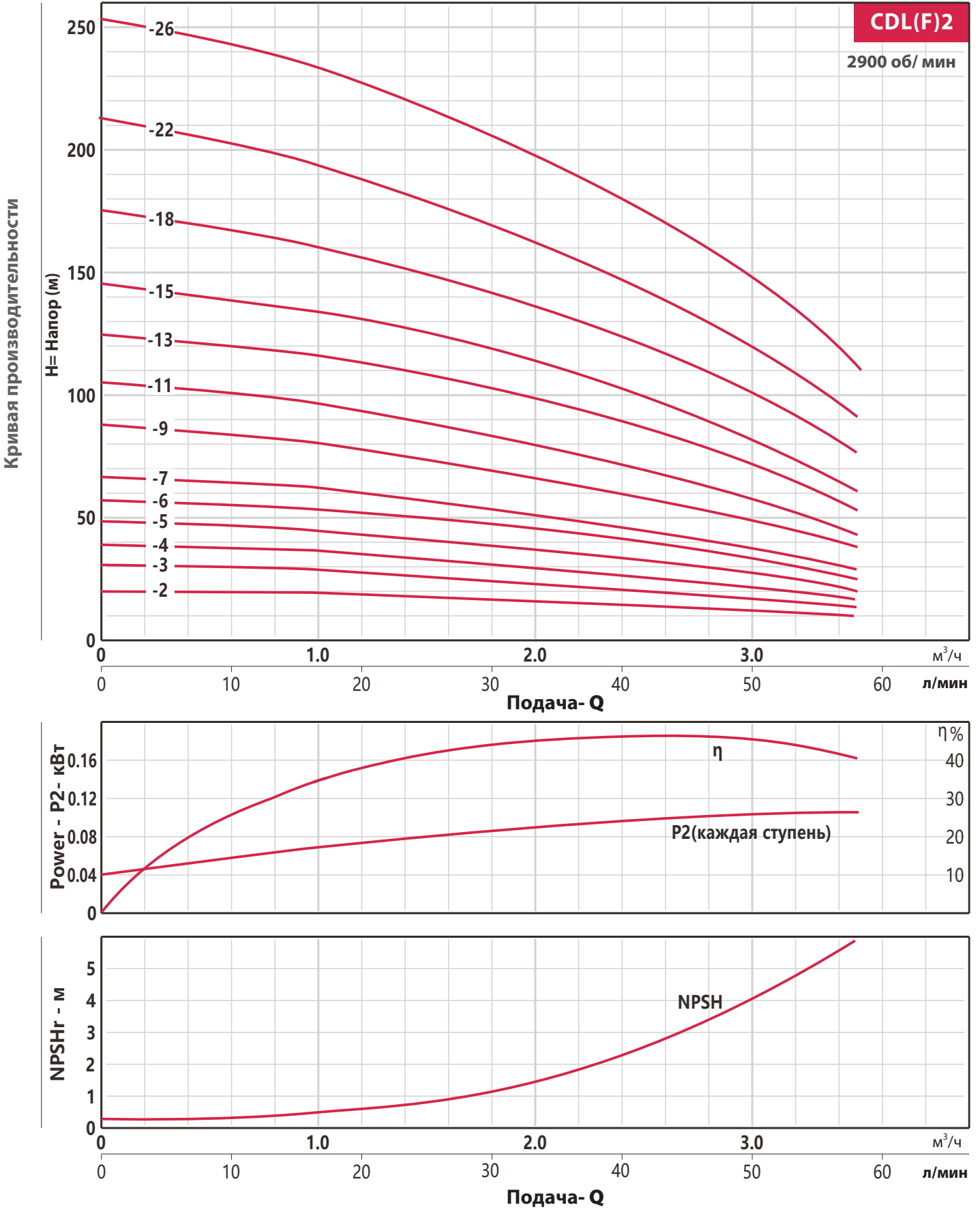

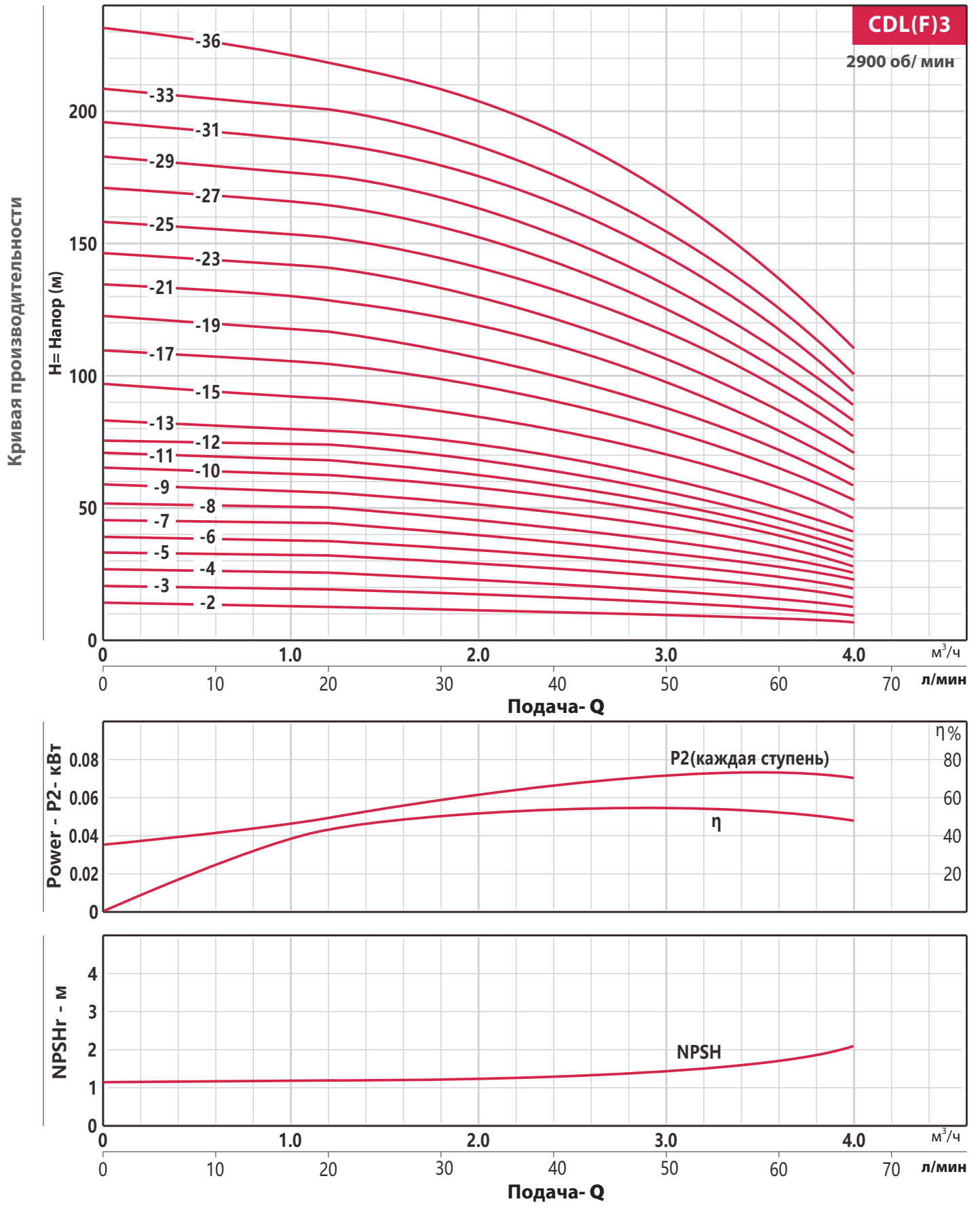

CDL(F)

CDL(F)4

2900 об/мин

Кривая производительности

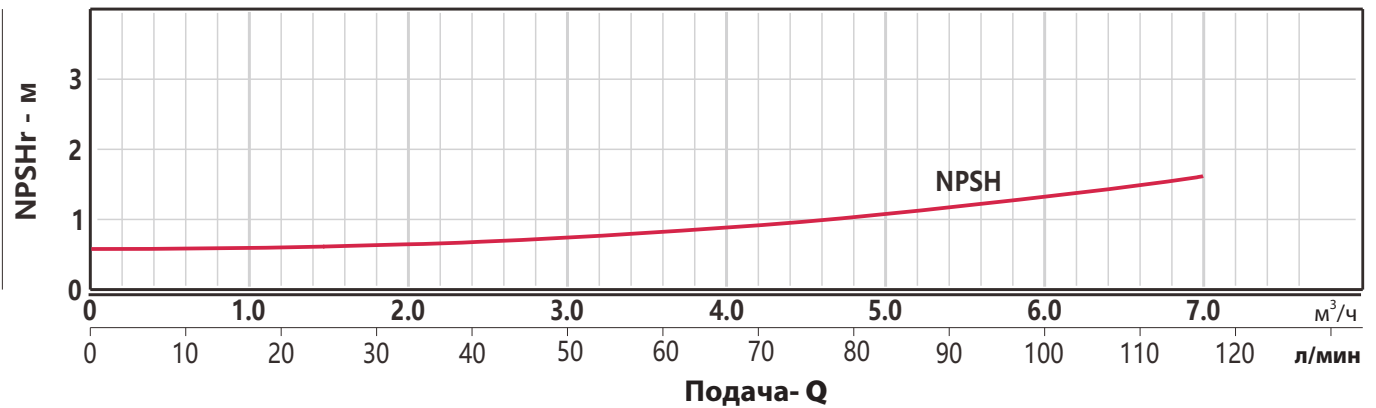
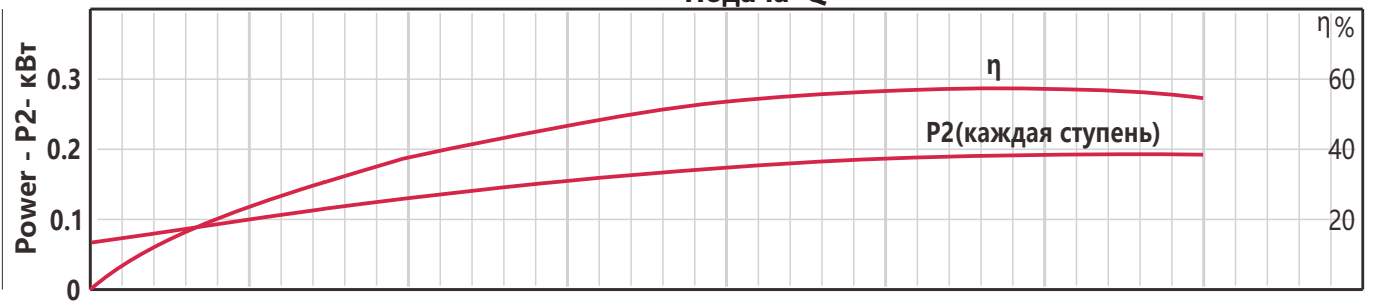
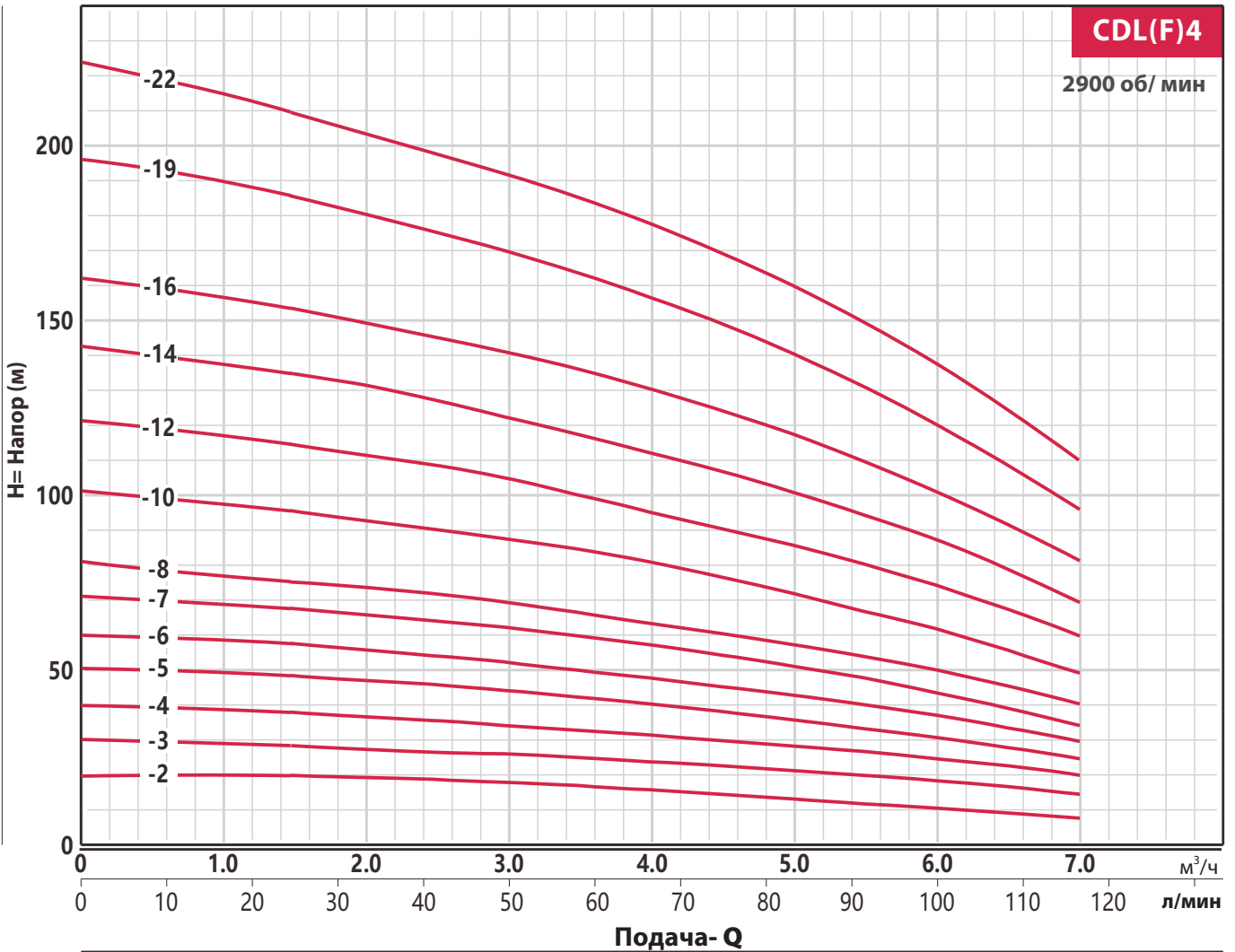

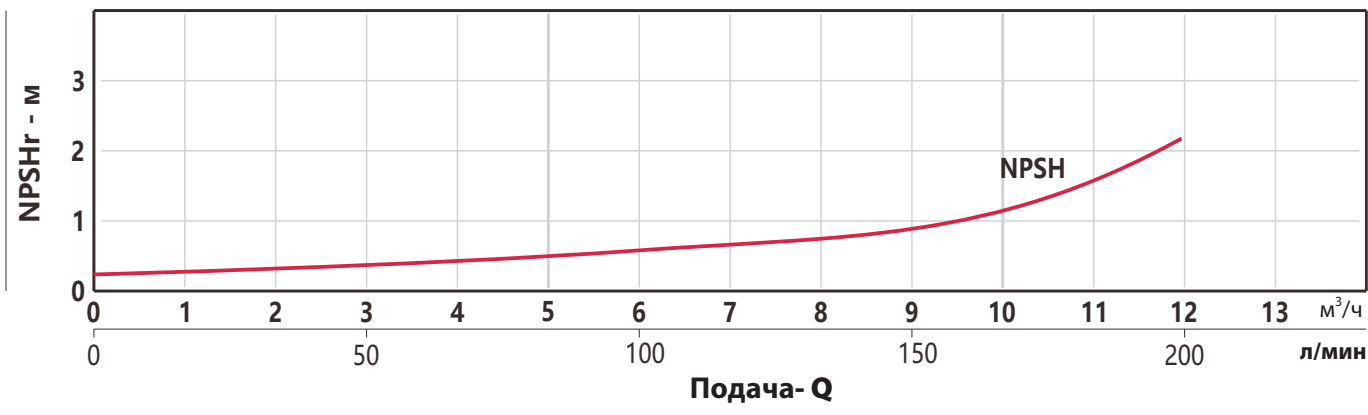
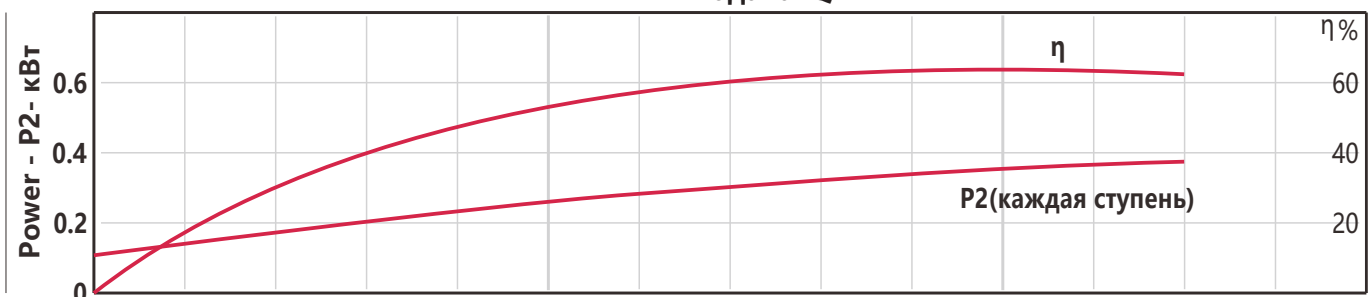
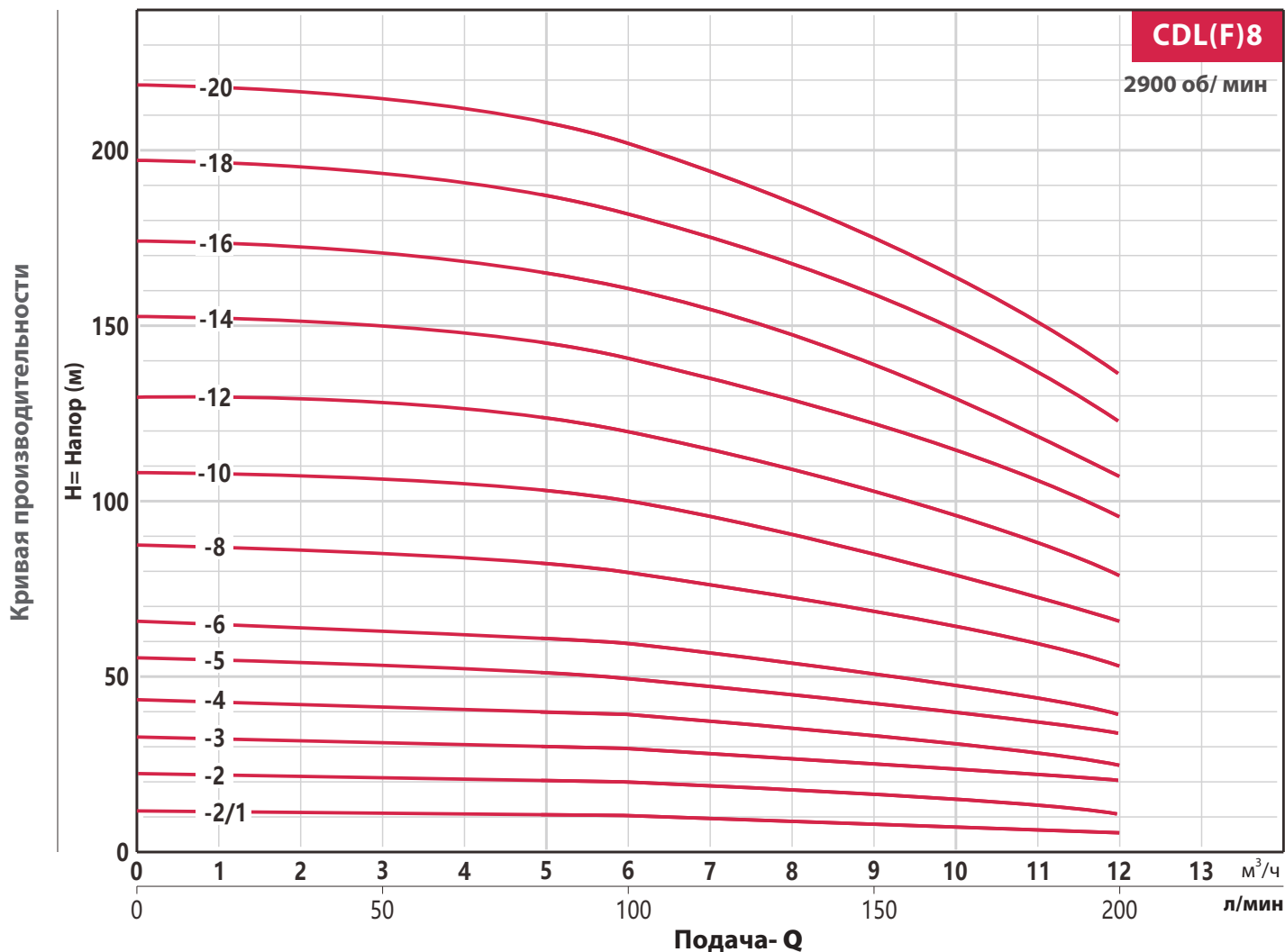

CDL(F)

CDL(F)10

2900 об/мин

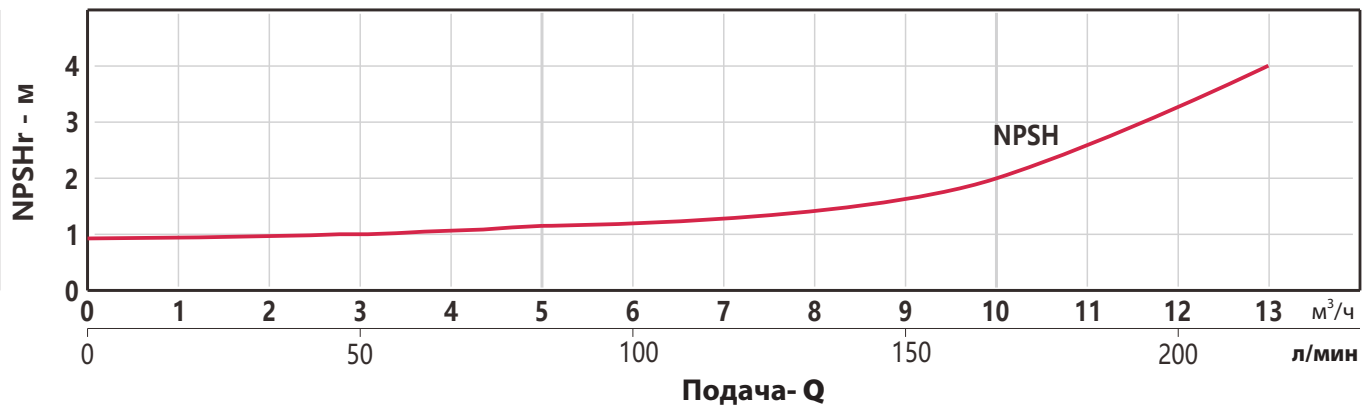
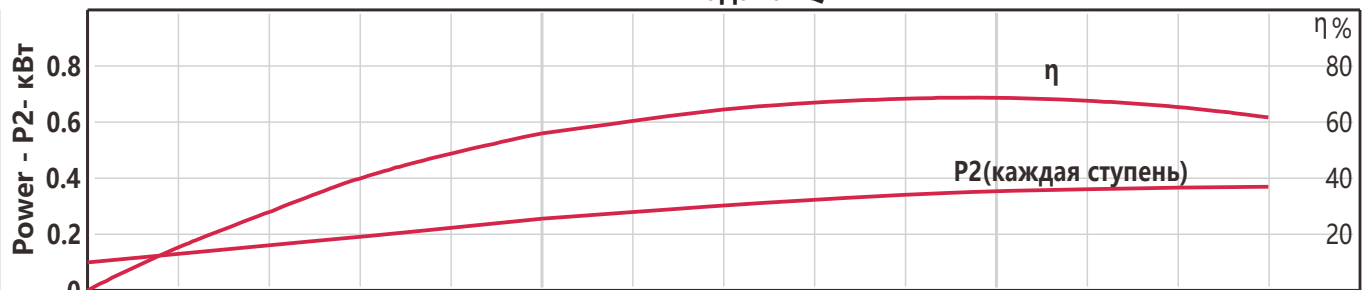
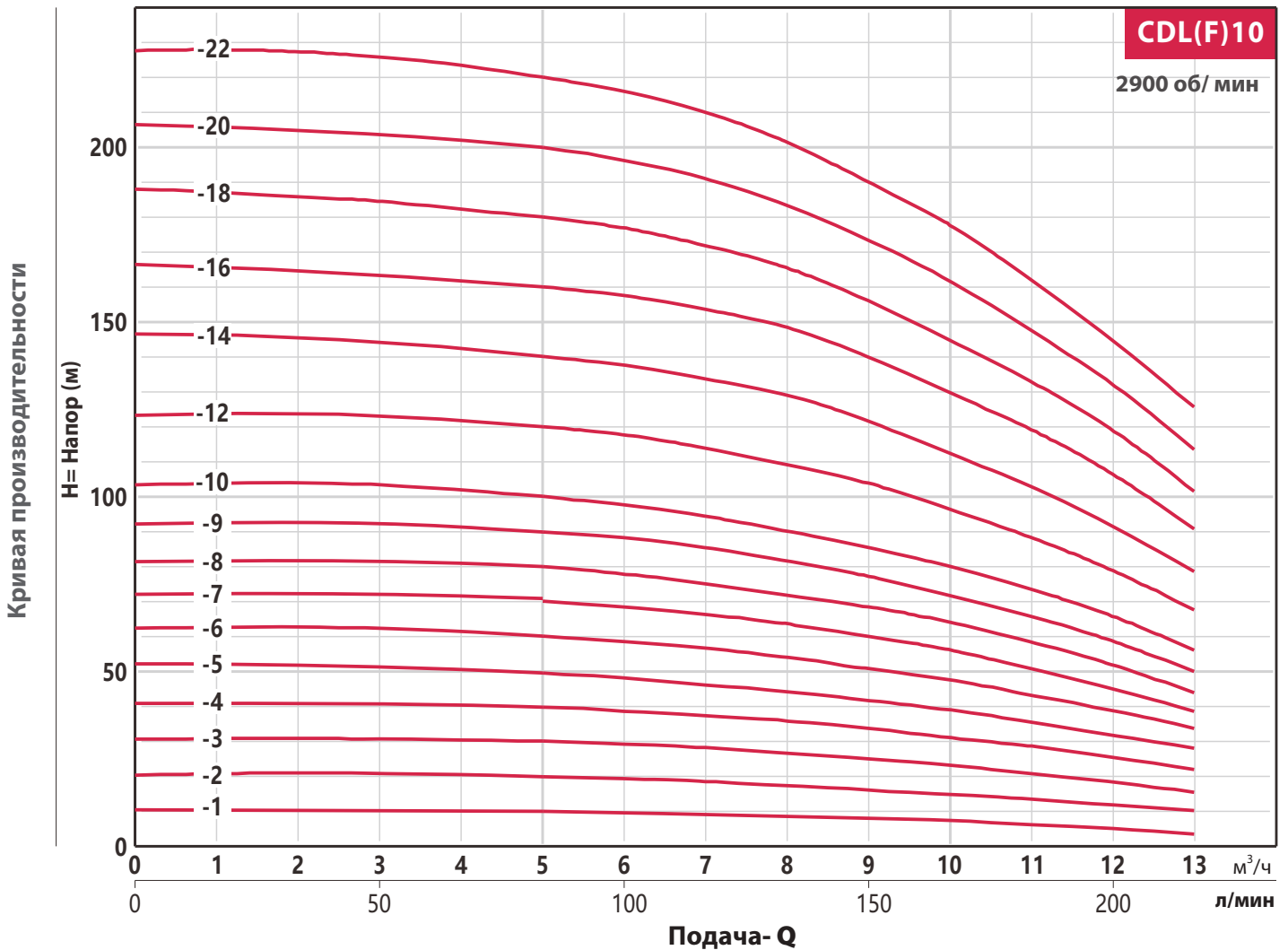

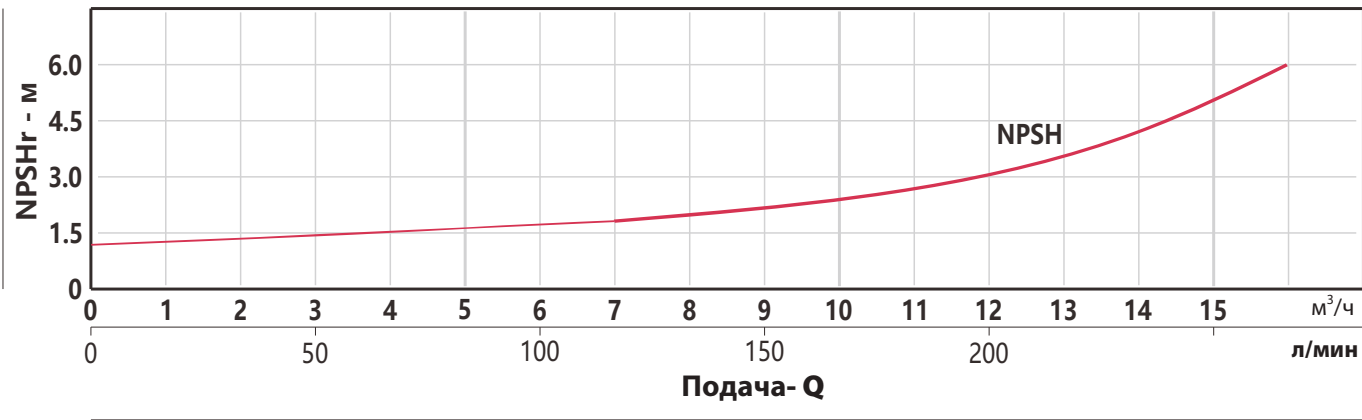
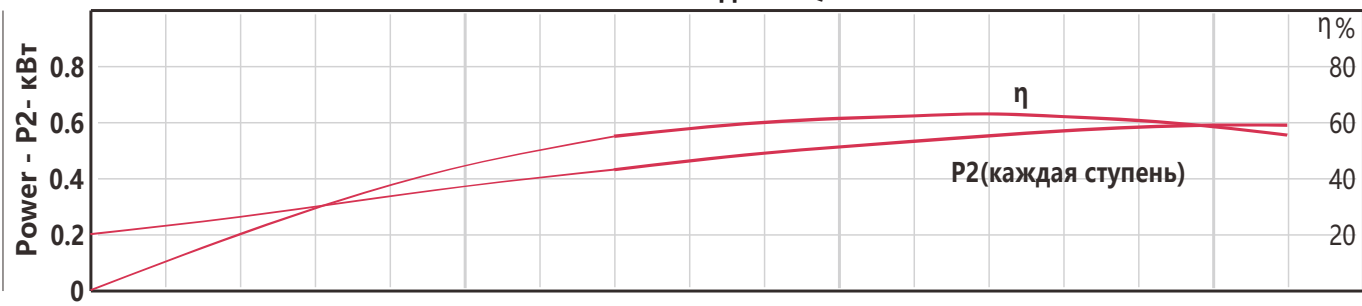
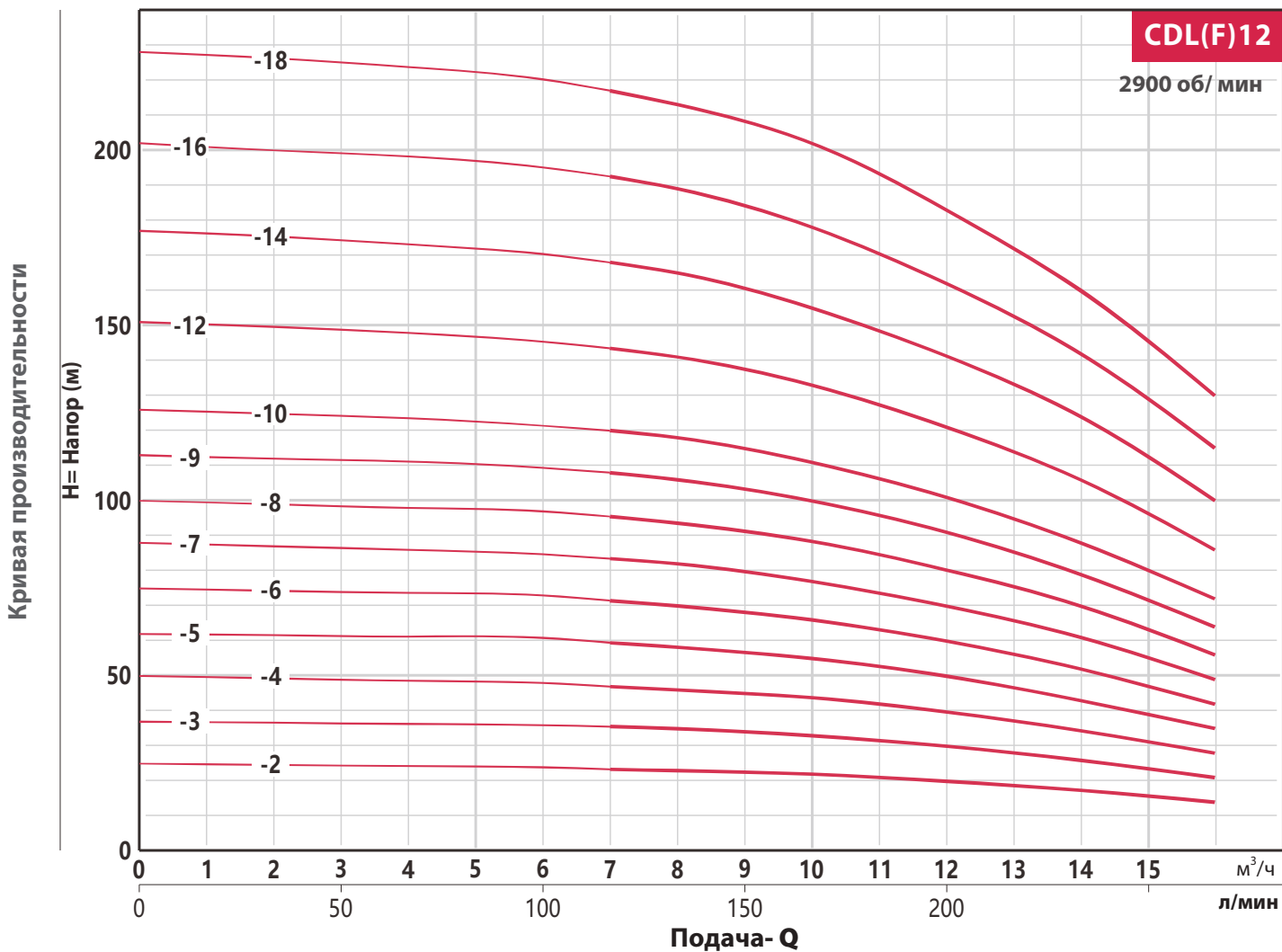

CDL(F)

CDL(F)16

2900 об/мин

Кривая производительности

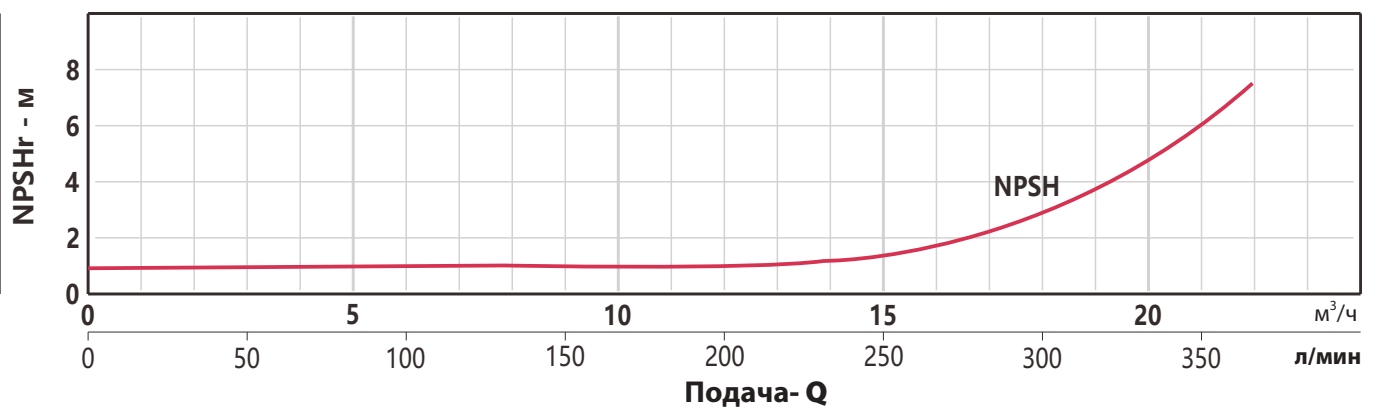
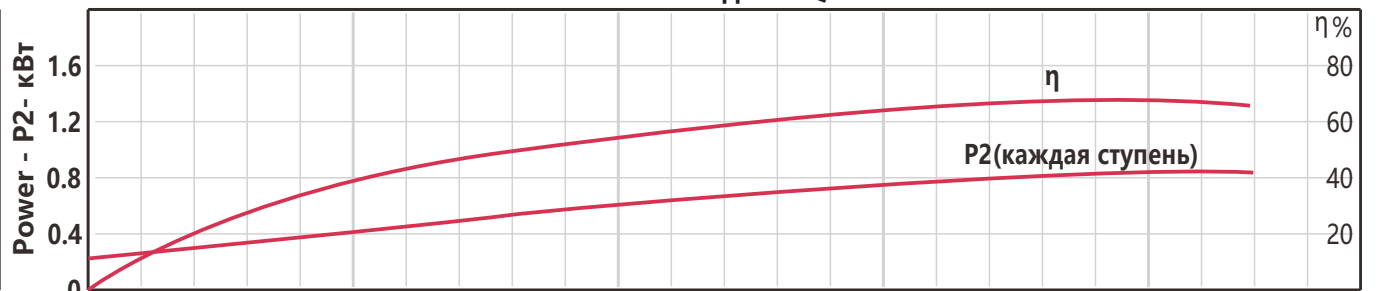
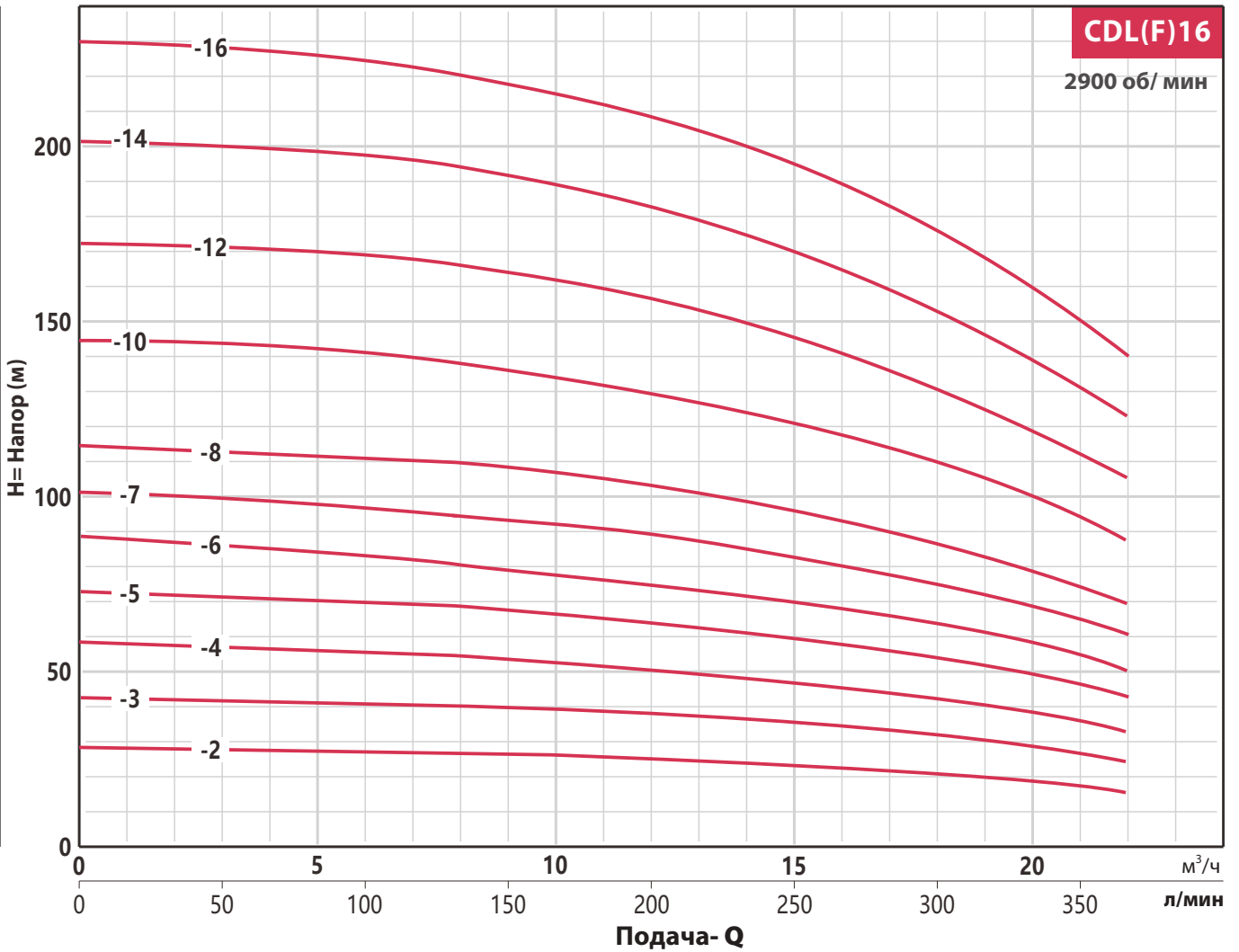

CDL(F)20

2900 об/мин

Кривая производительности

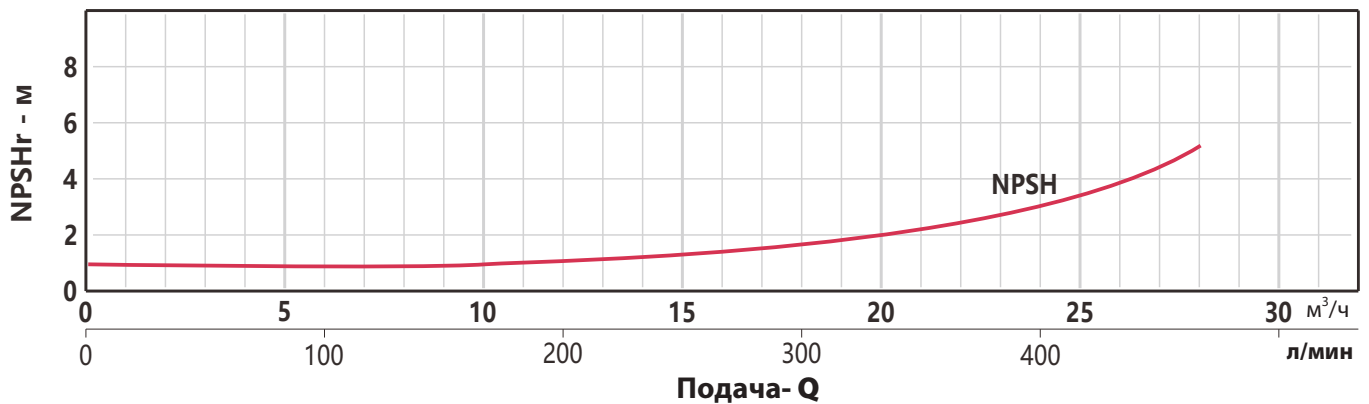
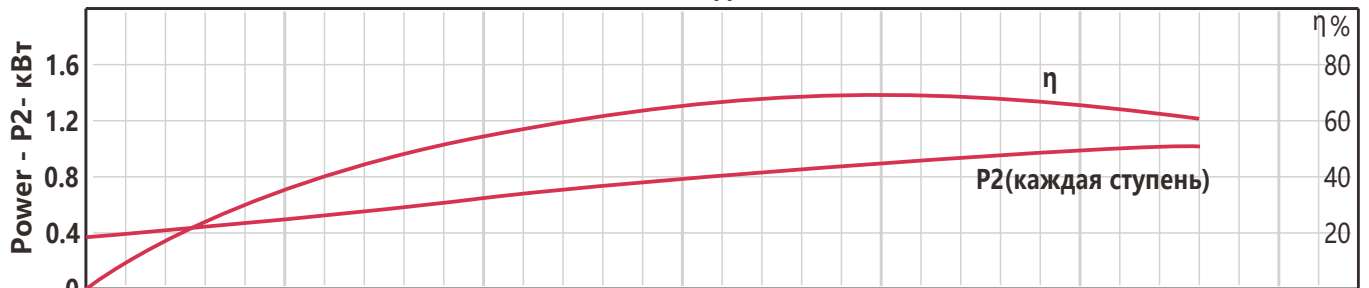
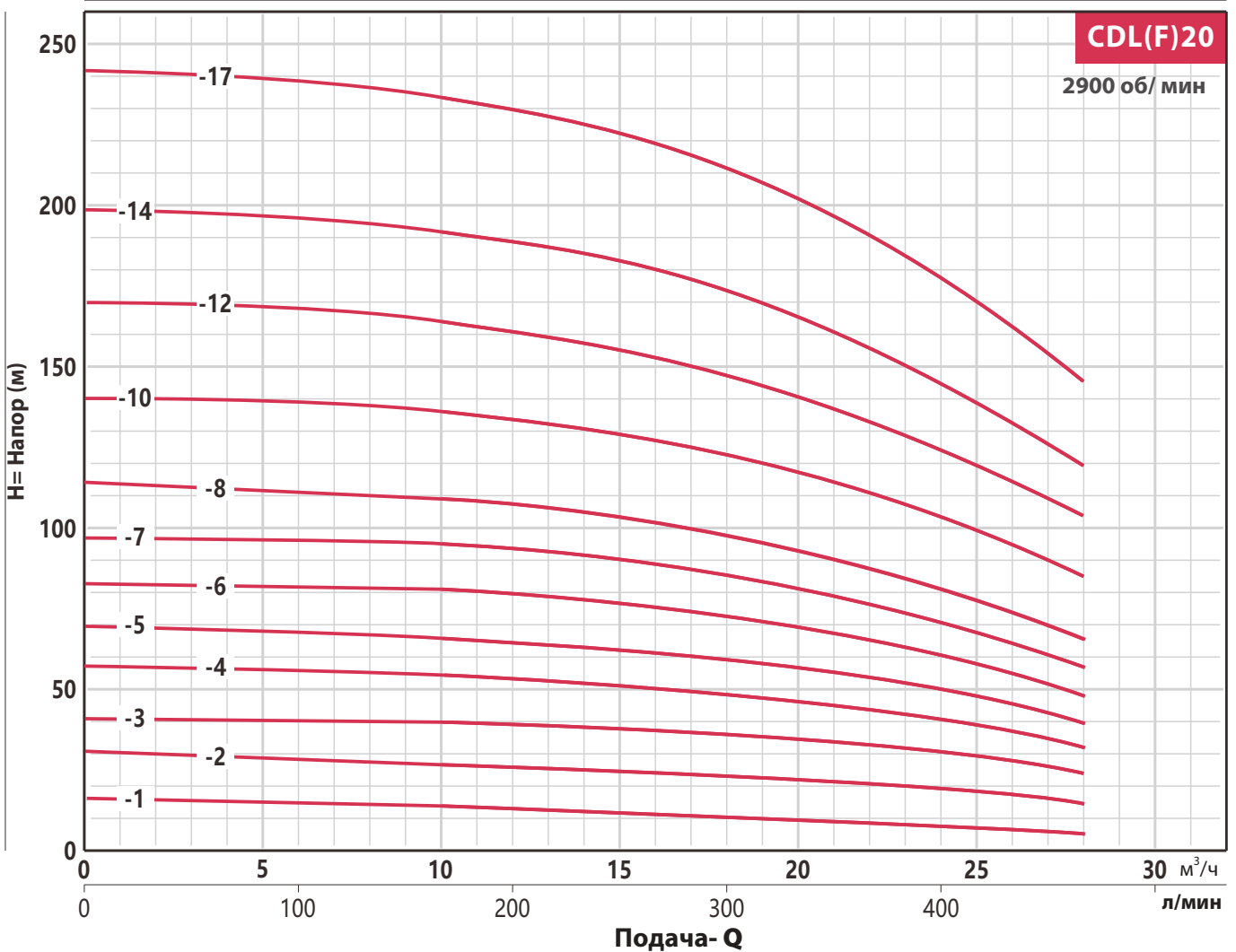

CDL(F)

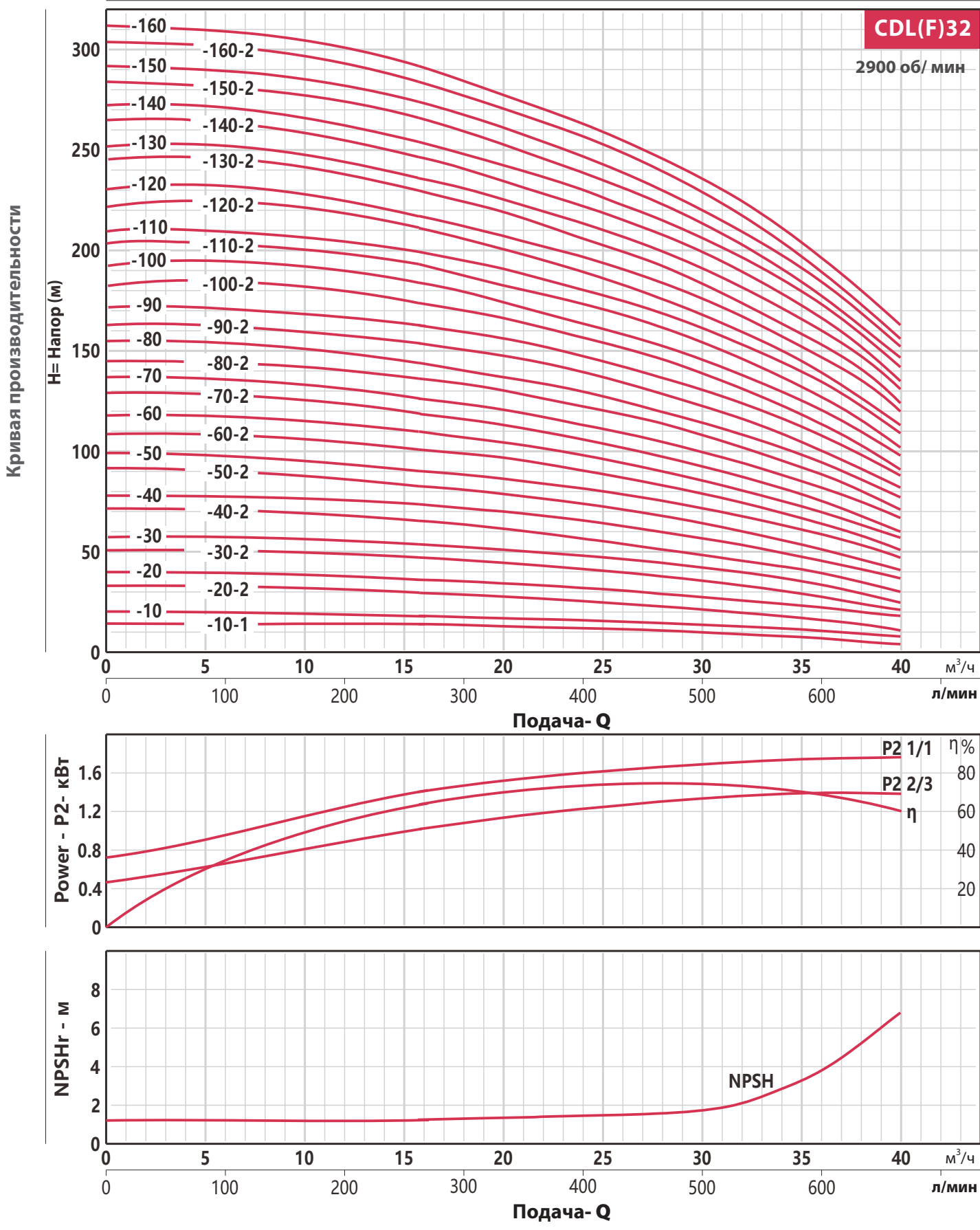

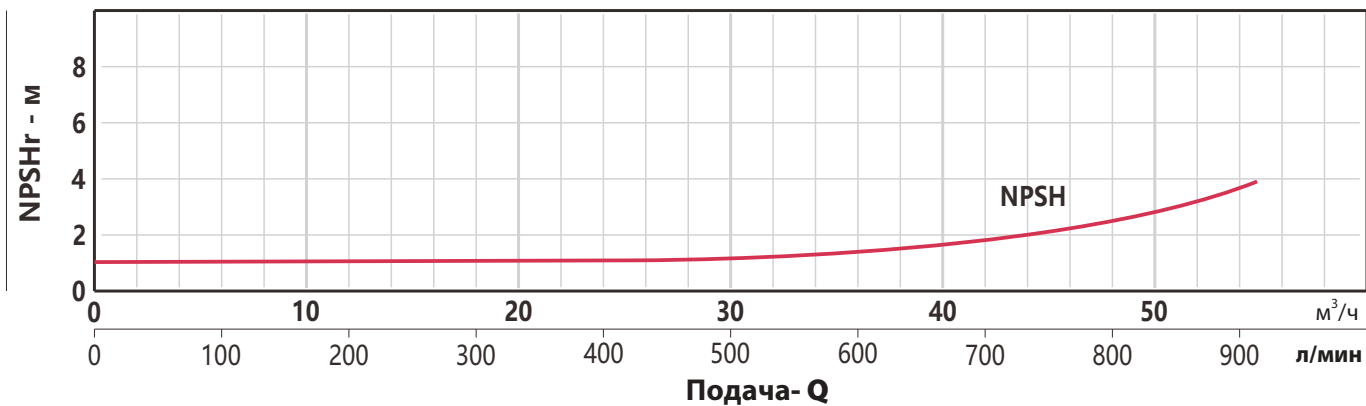
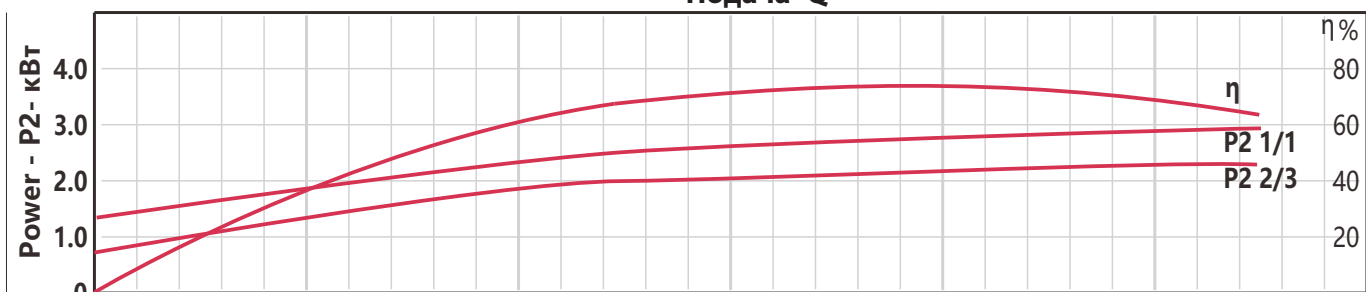
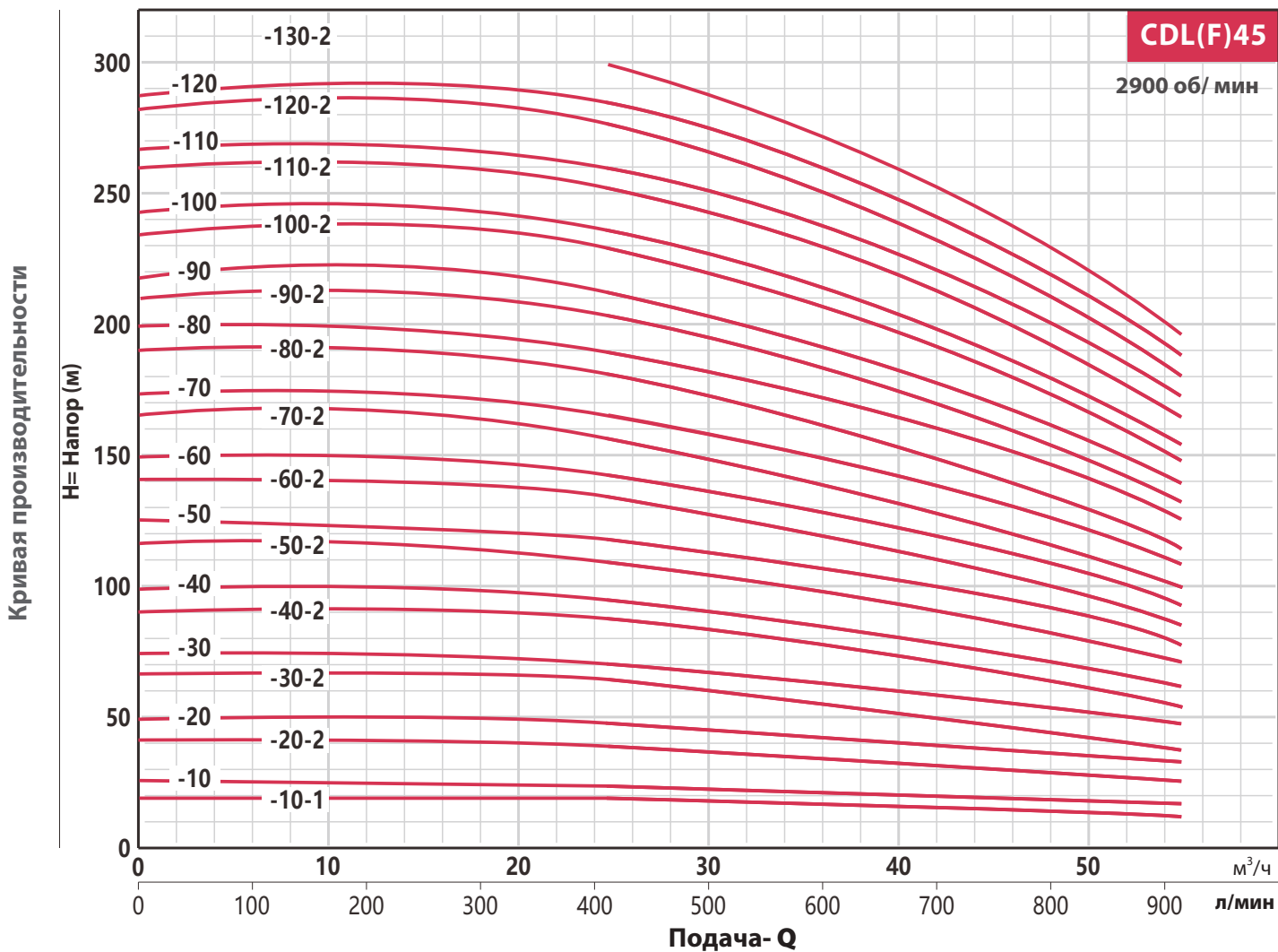

CDL(F)

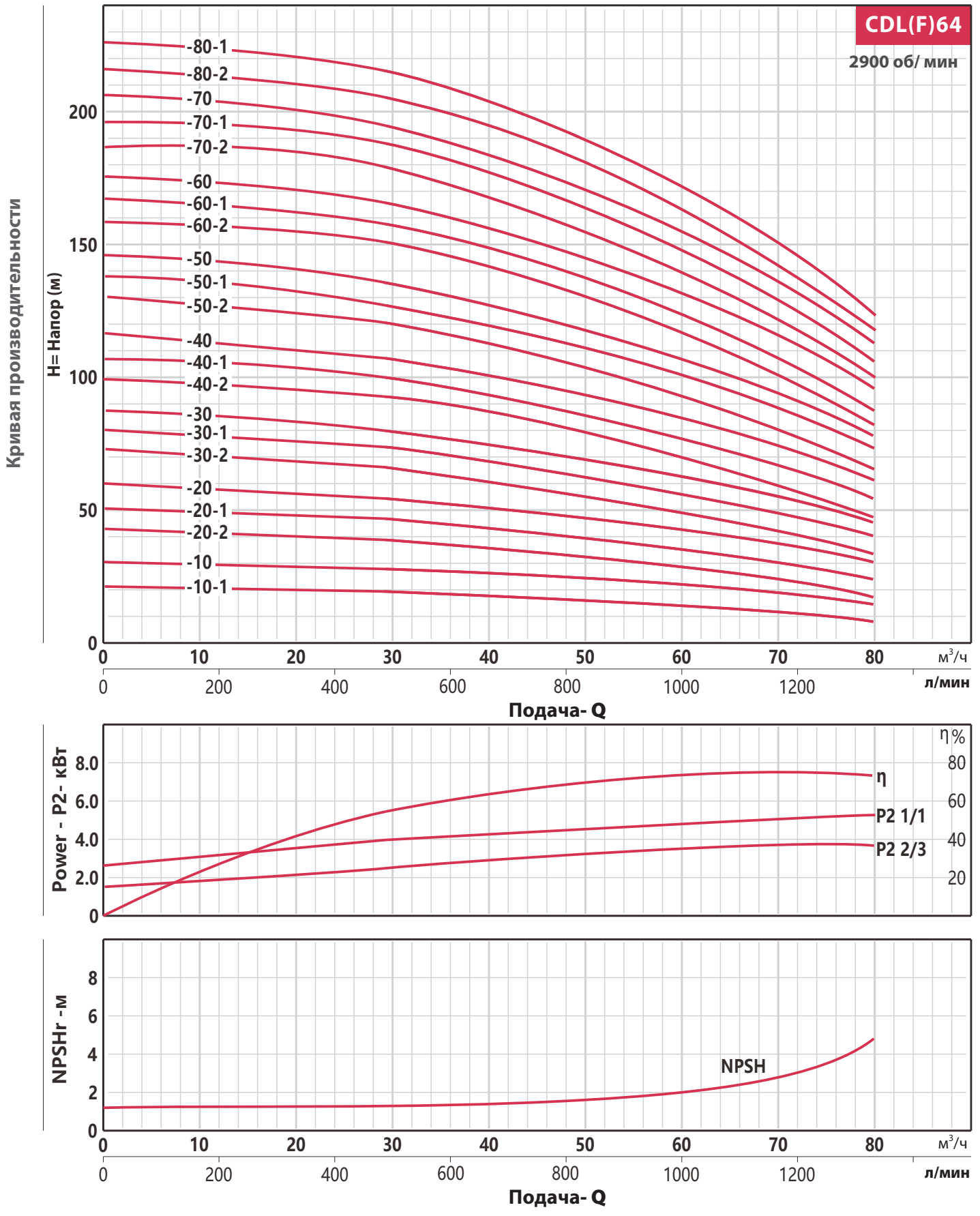

CDL(F)90

2900 об/мин

Кривая производительности

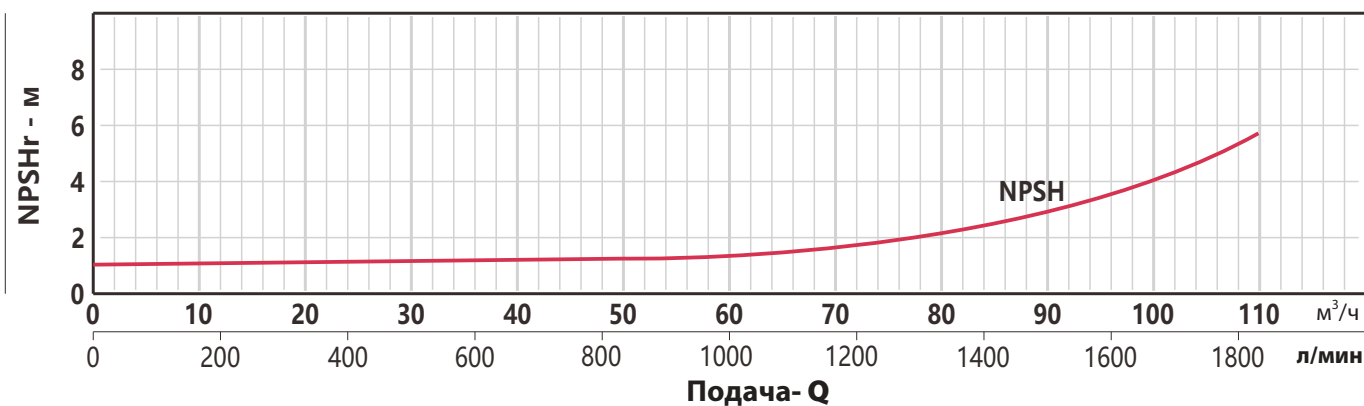
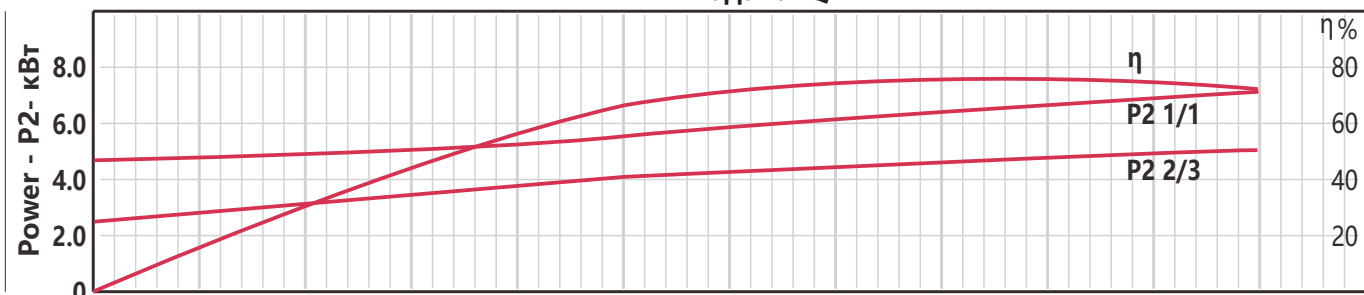
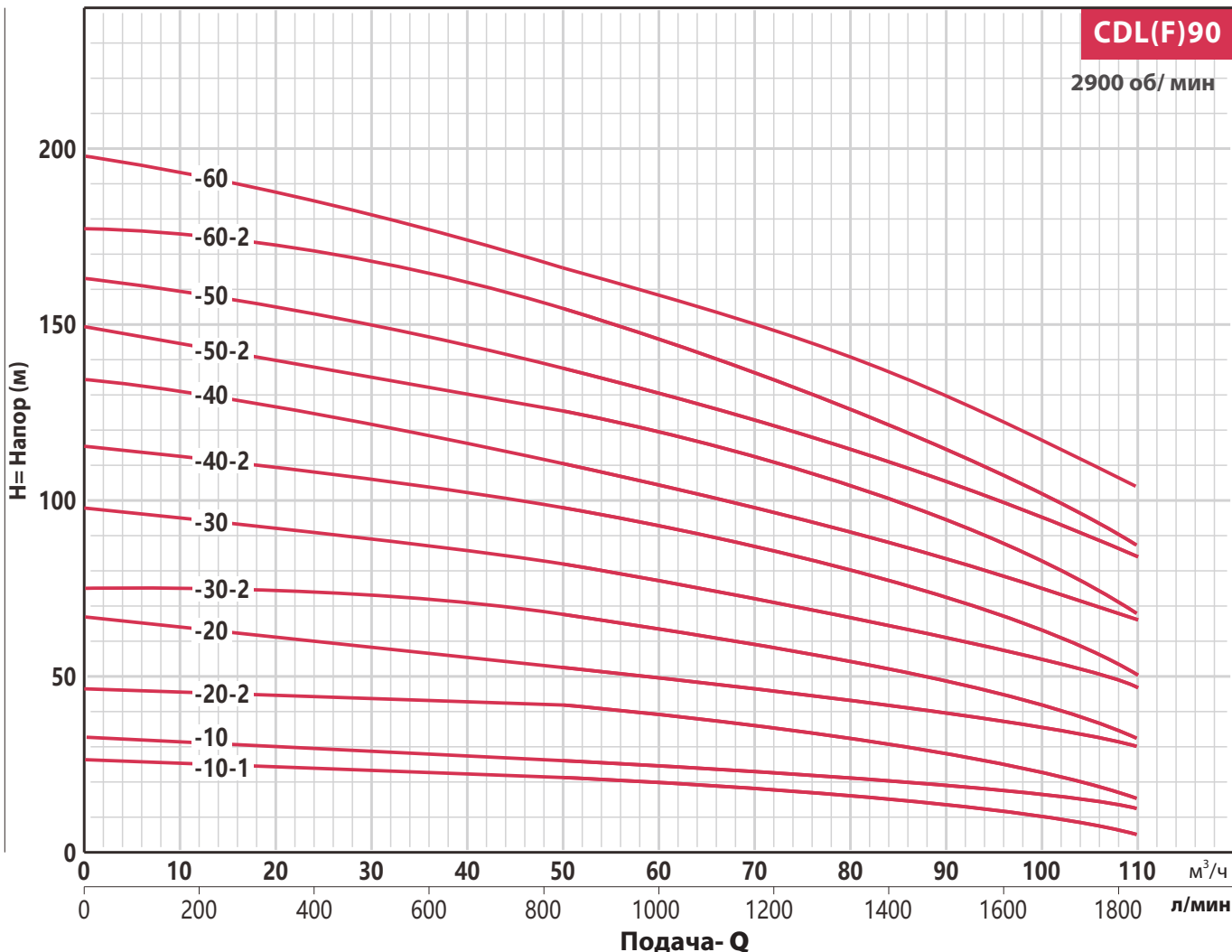

CDL(F)

CDL(F)120

2900 об/мин

Кривая производительности

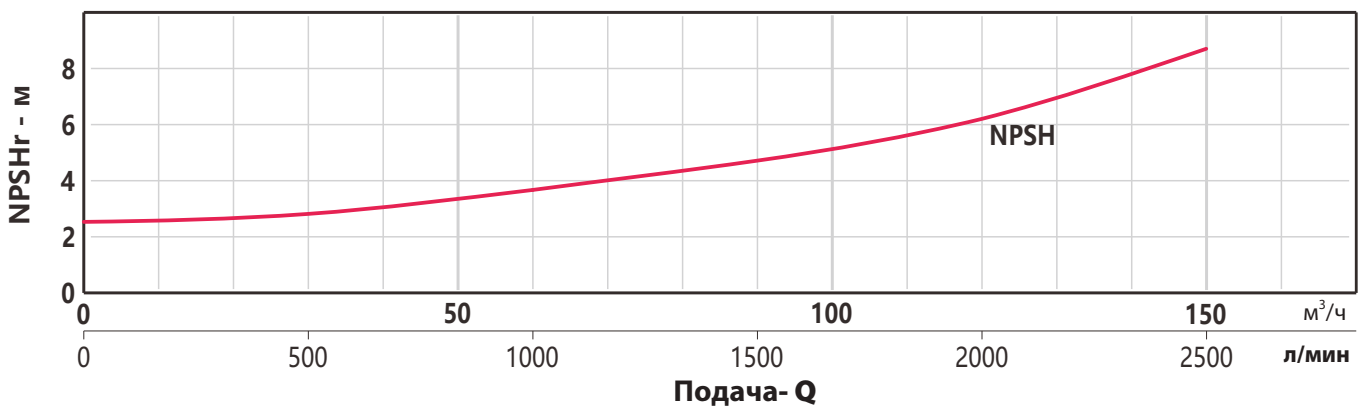
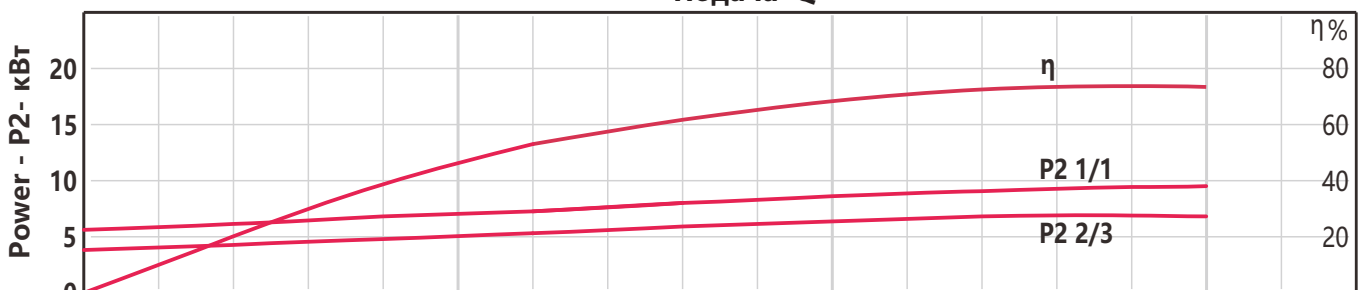
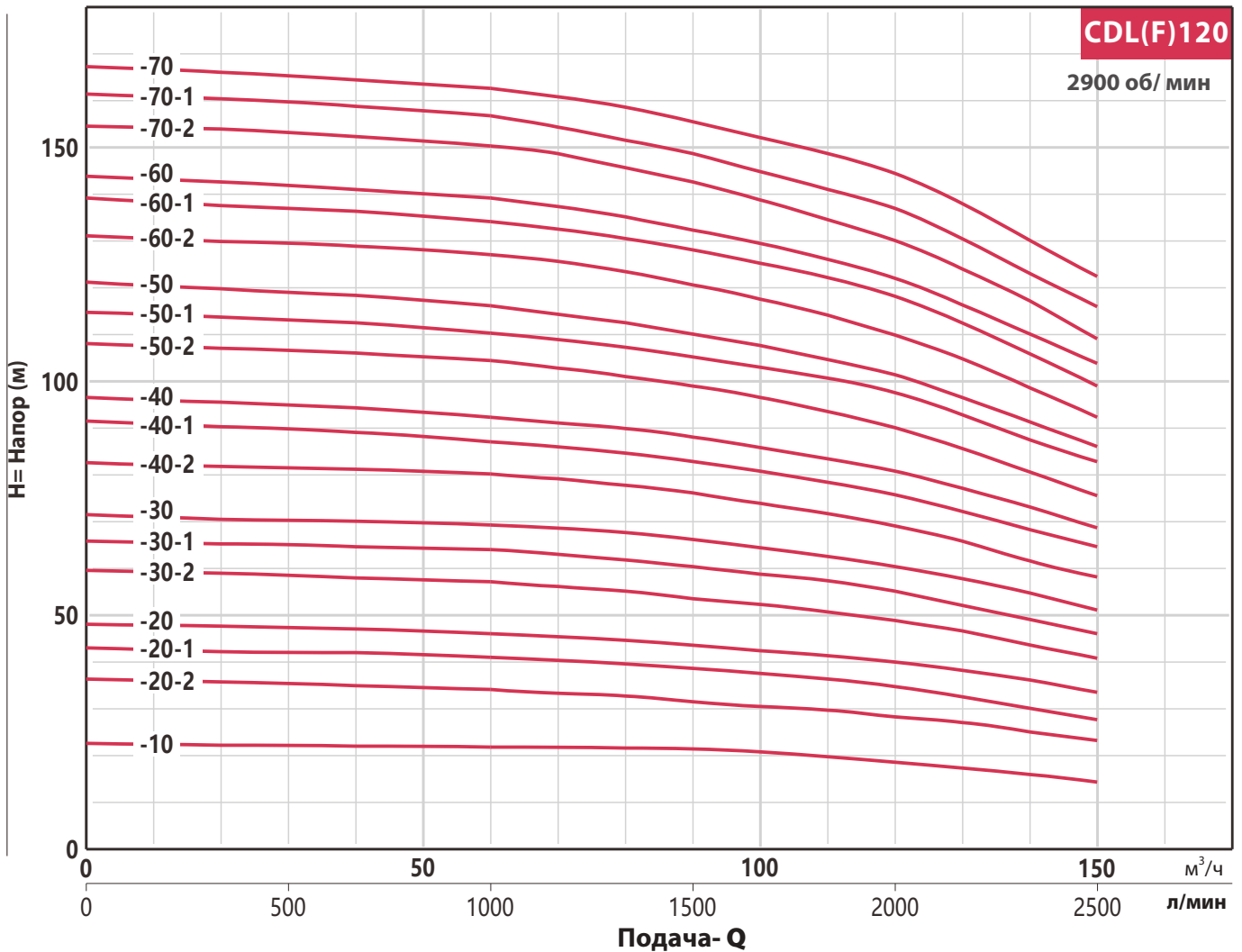

CDL(F)150
2900 об/мин

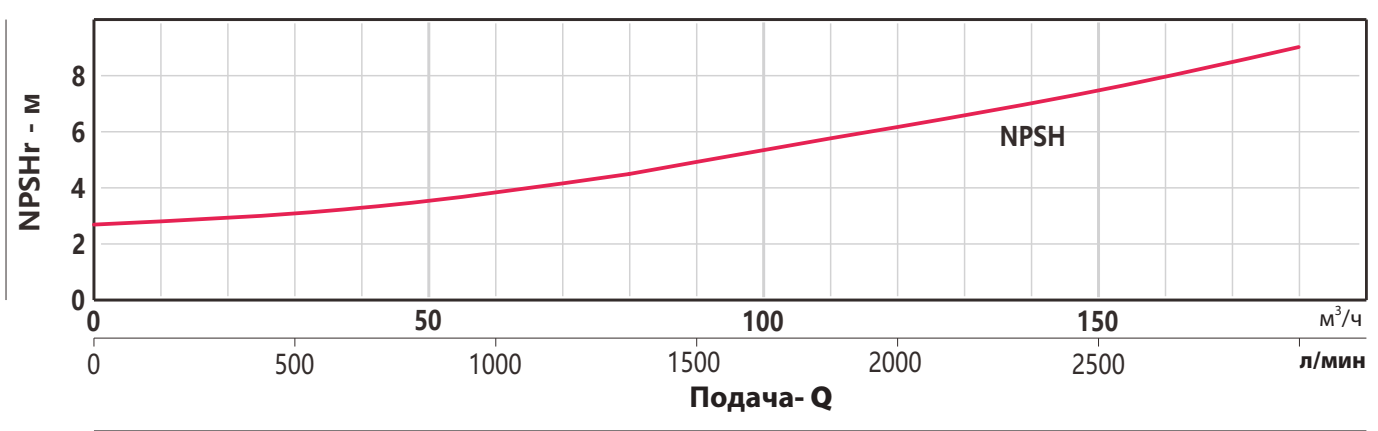
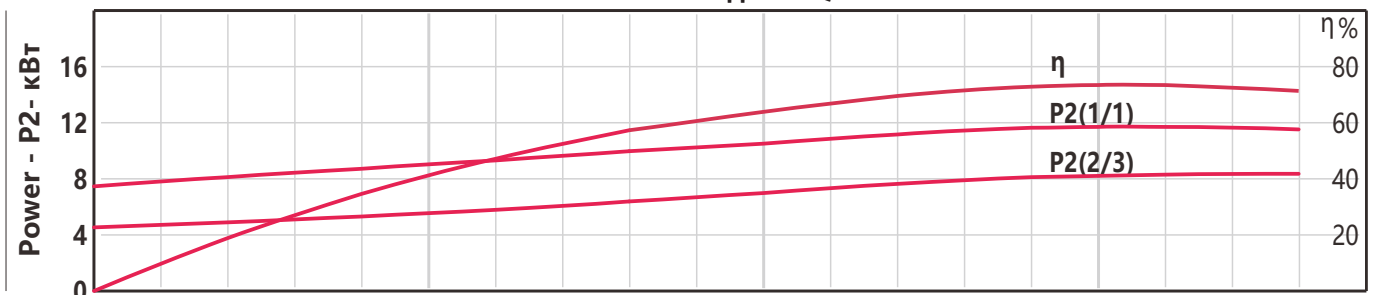
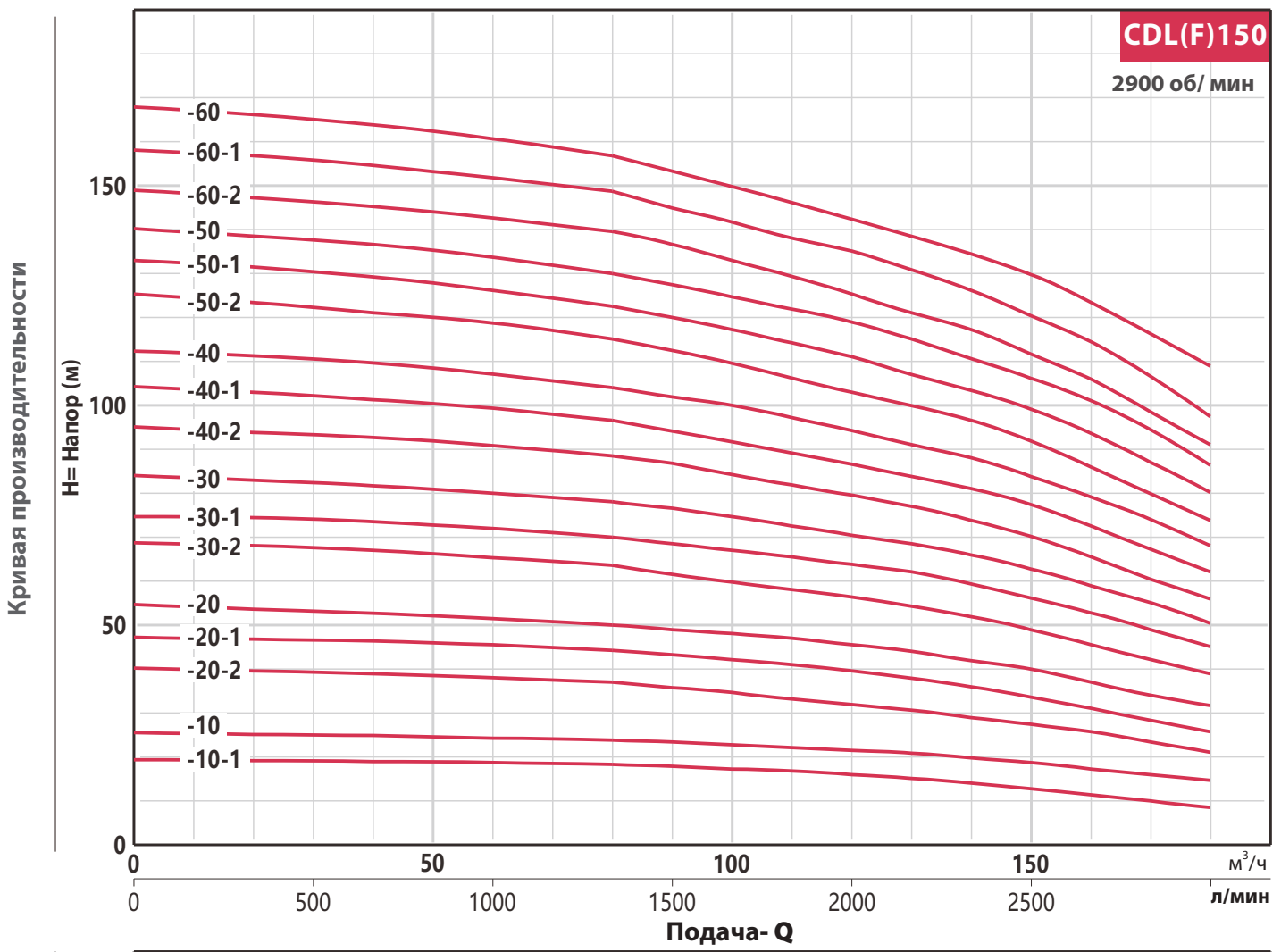

CDL(F)

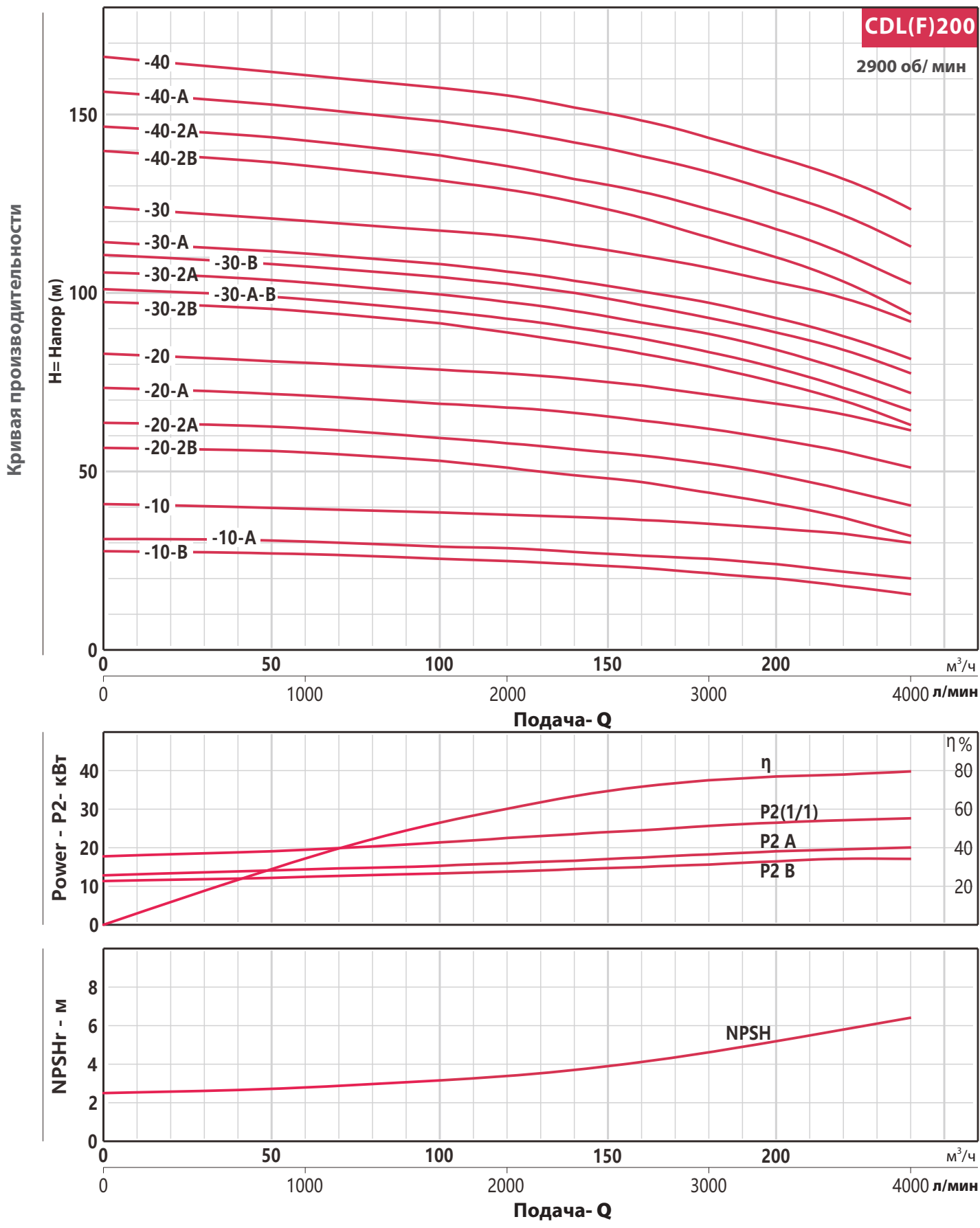



ОФИЦИАЛЬНЫЙ ДИЛЕР В РЕСПУБЛИКЕ БЕЛАРУСЬ



БЕЛТЕПЛОМАШ
СТРОЙ

ЦЕНТРАЛЬНЫЙ ОФИС

Минск, 220015, ул. Пономаренко, 35А-119
+375 17 301 10 00 – многоканальный
+375 29 680 35 99 – Viber, Telegram, WhatsApp
+375 29 757 72 30
+375 25 600 27 25

Отдел импортного насосного оборудования

+375 17 238-31-48
import@beltepl.by

ПРЕДСТАВИТЕЛЬСТВА:

БАРАНОВИЧСКИЙ ОФИС

Барановичи, 225409, ул. С. Лазо, 4
+375 29 750 68 87 – Viber
+375 29 316 95 26 – Viber
+375 163 64 39 42

БРЕСТСКИЙ ОФИС

Брест, 224032, ул. Я. Купалы, 102
+375 29 279 84 90 – Viber
+375 162 57 45 11, 55 10 86

ВИТЕБСКИЙ ОФИС

Витебск, 210038, ул. Бровки, 4а
+375 29 275 65 96
+375 44 511 52 85
+375 212 48 04 62, 48 04 59

ГОМЕЛЬСКИЙ ОФИС

Гомель, 246000, ул. 2-я Гражданская, 5
+375 29 270 04 96
+375 44 763 76 70
+375 232 25 65 37, 25 51 25

ГРОДНЕНСКИЙ ОФИС

Гродно, 230768, ул. Суворова, 256
+375 29 701 58 86 – Viber
+375 29 101 51 48
+375 152 62 44 97, 62 45 21

МОГИЛЕВСКИЙ ОФИС

Могилев, 212029, ул. Габровская, 11Б
+375 29 101 31 91 – Viber, Telegram
+375 29 765 33 76
+375 222 41 11 18, 41 11 17

ПИНСКИЙ ОФИС

Пинск, 225710, ул. Калиновского, 28
+375 29 275 21 61 – Viber
+375 29 110 97 21
+375 165 66 17 10, 66 16 48

beltepl.by
beltepl@beltep.by